

Models:

GRAND-I35
GRAND-I35-SP
SUPREME-I30
SUPREME-I30-SP

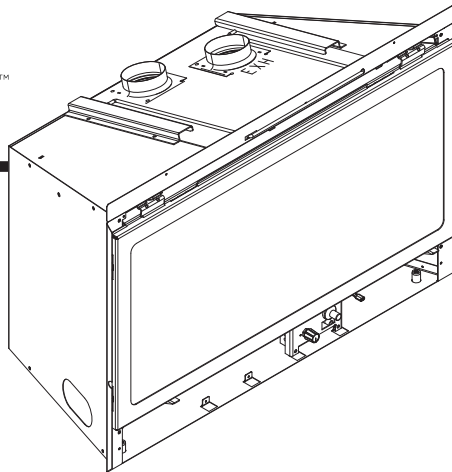

GAS-FIRED



NOTICE



DO NOT DISCARD THIS MANUAL

- Important operating and maintenance instructions included.
- Read, understand and follow these instructions for safe installation and operation.
- Leave this manual with party responsible for use and operation.

DO NOT
DISCARD

⚠ WARNING: If the information in these instructions is not followed exactly, a fire or explosion may result causing property damage, personal injury, or death.

- **DO NOT** store or use gasoline or other flammable vapors and liquids in the vicinity of this or any other appliance.
- **What to do if you smell gas**
 - **DO NOT** try to light any appliance.
 - **DO NOT** touch any electrical switch. **DO NOT** use any phone in your building.
 - Immediately call your gas supplier from a neighbor's phone. Follow the gas supplier's instructions.
 - If you cannot reach your gas supplier, call the fire department.
- Installation and service must be performed by a qualified installer, service agency, or the gas supplier.

This appliance may be installed as an OEM installation in manufactured home (USA only) or mobile home and must be installed in accordance with the manufacturer's instructions and the manufactured home construction and safety standard, *Title 24 CFR, Part 3280* or *Standard for Installation in Mobile Homes, CAN/CSA Z240MH*, in Canada.

This appliance is only for use with the type(s) of gas indicated on the rating plate.

⚠ WARNING



HOT SURFACES!

Glass and other surfaces are hot during operation AND cool down.

Hot glass will cause burns.

- **DO NOT** touch glass until it is cooled
 - NEVER allow children to touch glass
 - Keep children away
 - CAREFULLY SUPERVISE children in same room as fireplace.
 - Alert children and adults to hazards of high temperatures.
- High temperatures may ignite clothing or other flammable materials.**
- Keep clothing, furniture, draperies and other flammable materials away.

This appliance has been supplied with an integral barrier to prevent direct contact with the fixed glass panel. DO NOT operate the appliance with the barrier removed.

Contact your dealer or Hearth & Home Technologies if the barrier is not present or help is needed to properly install one.

In the Commonwealth of Massachusetts installation must be performed by a licensed plumber or gas fitter.

A CO detector shall be installed in the room where the appliance is installed.



Installation and service of this appliance should be performed by qualified personnel. Hearth & Home Technologies suggests NFI certified or factory trained professionals, or technicians supervised by an NFI certified professional.

Read this manual before installing or operating this appliance.
Please retain this owner's manual for future reference.

A. Congratulations

Congratulations on selecting a Heat & Glo gas fireplace, an elegant and clean alternative to wood burning fireplaces. The Heat & Glo gas fireplace you have selected is designed to provide the utmost in safety, reliability, and efficiency.

As the owner of a new fireplace, you'll want to read and carefully follow all of the instructions contained in this *Owner's Manual*. Pay special attention to all cautions and warnings.

This *Owner's Manual* should be retained for future reference. We suggest that you keep it with your other important documents and product manuals.

The information contained in this *Owner's Manual*, unless noted otherwise, applies to all models and gas control systems.

Your new Heat & Glo gas fireplace will give you years of durable use and trouble-free enjoyment. Welcome to the Heat & Glo family of fireplace products!

Homeowner Reference Information	<i>We recommend that you record the following pertinent information about your fireplace.</i>
Model Name: _____	Date purchased/installed: _____
Serial Number: _____	Location on fireplace: _____
Dealership purchased from: _____	Dealer Phone: _____
Notes: _____	

Listing Label Information/Location

The model information regarding your specific fireplace can be found on the rating plate usually located in the control area of the fireplace.



No one builds a better fire

Heat & Glo, a brand of Hearth & Home Technologies, Inc.
7571 215th Street West, Lakeville, MN 55044

GAS-FIRED



Not for use with solid fuel.
(Ne doit pas être utilisé avec un combustible solide).

Type of Gas (*Sorte De Gaz*): **NATURAL GAS** This appliance must be installed in accordance with local codes, if any; if not, follow ANSI Z223.1 in the USA or CAN/CGA B149 installation codes. (Installer l'appareil selon les codes ou règlements locaux ou, en l'absence de tels règlements, selon les codes d'installation CAN/CGA-B149.)

ANSI Z21XX-XXXX · CSA 2.XX-MXX · UL307B

Minimum Permissible Gas Supply for Purposes of Input Adjustment.

Approved Minimum (<i>De Gaz</i>) Acceptable	0.0 in w.c.	(<i>Po. Col. d'eau</i>)
Maximum Pressure (<i>Pression</i>)	0.0 in w.c.	(<i>Po. Col. d'eau</i>)
Maximum Manifold Pressure (<i>Pression</i>)	0.0 in w.c.	(<i>Po. Col. d'eau</i>)
Minimum Manifold Pressure (<i>Pression</i>)	0.0 in w.c.	(<i>Po. Col. d'eau</i>)

Total Electrical Requirements: 000Vac, 00Hz., less than 00 Amperes

MADE IN USA

		Model:	XXXXXXXX
		(Modele):	_____
		Serial	XXXXXXXX
		(Serie):	_____

		IN CANADA	
ALTITUDE:	0-0000 FT.	0000-0000FT.	
MAX. INPUT BTUH:	00,000	00,000	
MIN. INPUT BTUH:	00,000	00,000	
ORIFICE SIZE:	#XXXXX	#XXXXX	

▲ Safety Alert Key:

- **DANGER!** Indicates a hazardous situation which, if not avoided will result in death or serious injury.
- **WARNING!** Indicates a hazardous situation which, if not avoided could result in death or serious injury.
- **CAUTION!** Indicates a hazardous situation which, if not avoided, could result in minor or moderate injury.
- **NOTICE:** Used to address practices not related to personal injury.

Table of Contents

A. Congratulations	2
B. Limited Lifetime Warranty	4

1 Listing and Code Approvals

A. Appliance Certification	6
B. Glass Specifications	6
C. BTU Specifications	6
D. High Altitude Installations	6
E. Non-Combustible Materials Specification	6
F. Combustible Materials Specification	6
G. Electrical Codes	6

User Guide

2 Operating Instructions

A. Gas Fireplace Safety	7
B. Your Fireplace	7
C. Clear Space	8
D. Decorative Doors, Fronts and Surrounds	8
E. Fixed Glass Assembly	8
F. Remote Controls, Wall Controls and Wall Switches	8
G. IPI Battery Tray/Battery Installation	8
→ H. Control Module Operation	8
I. Before Lighting Fireplace	9
J. Lighting Instructions (IPI)	10
K. After Appliance is Lit	12
L. Frequently Asked Questions	12

3 Maintenance and Service

A. Maintenance Tasks-Homeowner	13
B. Maintenance Tasks-Service Technician	14

Installer Guide

4 Getting Started

A. Typical Appliance System	16
B. Design and Installation Considerations	17
C. Tools and Supplies Needed	17
D. Inspect Appliance and Components	17

5 Fireplace Size Requirements

A. Minimum Fireplace Opening	18
B. Mantel and Wall Projections	19

6 Termination Locations

A. Vent Termination Minimum Clearances	20
--	----

7 Installation Preparation

A. Inspection and Cleaning	21
B. Flue Damper	21

C. Gas Line	21
D. Fireplace Conversion Notice	21
E. Electrical Outlet Box	21

8 Installing Vent Pipe and Appliance

A. Vent Limits	22
B. Venting Components	22
C. Connecting Vent Pipe	22
D. Placing, Securing and Leveling the Appliance	23
E. Remote Control	23
F. Installing Adaptor and Termination Cap	24

9 Gas Information

A. Fuel Conversion	25
B. Gas Pressure	25
C. Gas Connection	25
D. High Altitude Installations	25

10 Electrical Information

A. Wiring Requirements	26
B. Standing Pilot Ignition System Wiring	26
C. IntelliFire Plus™ Ignition System Wiring	26
D. Optional Accessories Requirements	28
E. Fan Wiring with Remote	29
F. Control Module Operation	29

11 Finishing

A. Mantel and Wall Projections	30
--	----

12 Appliance Setup

A. Remove Glass Assembly	31
B. Remove the Shipping Materials	31
C. Clean the Appliance	31
D. Accessories	31
E. Place the Lava Rock	31
F. Ember Placement	31
G. Install the Log Assembly	32 ←
H. Fixed Glass Assembly	37
I. Air Shutter Setting	37

13 Troubleshooting

A. Standing Pilot Ignition System	38
B. IntelliFire Plus™ Ignition System	40

14 Reference Materials

A. Appliance Dimension Diagram	41
B. Vent Kits Components	42 ←
C. Service Parts List	47
D. Contact Information	48

B. Limited Lifetime Warranty

Hearth & Home Technologies Inc. LIMITED LIFETIME WARRANTY

Hearth & Home Technologies Inc., on behalf of its hearth brands ("HHT"), extends the following warranty for HHT gas, wood, pellet, coal and electric hearth appliances that are purchased from an HHT authorized dealer.

WARRANTY COVERAGE:

HHT warrants to the original owner of the HHT appliance at the site of installation, and to any transferee taking ownership of the appliance at the site of installation within two years following the date of original purchase, that the HHT appliance will be free from defects in materials and workmanship at the time of manufacture. After installation, if covered components manufactured by HHT are found to be defective in materials or workmanship during the applicable warranty period, HHT will, at its option, repair or replace the covered components. HHT, at its own discretion, may fully discharge all of its obligations under such warranties by replacing the product itself or refunding the verified purchase price of the product itself. The maximum amount recoverable under this warranty is limited to the purchase price of the product. This warranty is subject to conditions, exclusions and limitations as described below.

WARRANTY PERIOD:

Warranty coverage begins on the date of original purchase. In the case of new home construction, warranty coverage begins on the date of first occupancy of the dwelling or six months after the sale of the product by an independent, authorized HHT dealer/ distributor, whichever occurs earlier. The warranty shall commence no later than 24 months following the date of product shipment from HHT, regardless of the installation or occupancy date. The warranty period for parts and labor for covered components is produced in the following table.

The term "Limited Lifetime" in the table below is defined as: 20 years from the beginning date of warranty coverage for gas appliances, and 10 years from the beginning date of warranty coverage for wood, pellet, and coal appliances. These time periods reflect the minimum expected useful lives of the designated components under normal operating conditions.

Warranty Period		HHT Manufactured Appliances and Venting							Components Covered
Parts	Labor	Gas	Wood	Pellet	EPA Wood	Coal	Electric	Venting	
1 Year		X	X	X	X	X	X	X	All parts and material except as covered by Conditions, Exclusions, and Limitations listed
2 years				X	X	X			Igniters, electronic components, and glass
		X	X	X	X	X			Factory-installed blowers
			X						Molded refractory panels
3 years				X					Firepots and burnpots
5 years	1 year			X	X				Castings and baffles
7 years	3 years		X	X	X				Manifold tubes, HHT chimney and termination
10 years	1 year	X							Burners, logs and refractory
Limited Lifetime	3 years	X	X	X	X	X			Firebox and heat exchanger
90 Days		X	X	X	X	X	X	X	All replacement parts beyond warranty period

See conditions, exclusions, and limitations on next page.

B. Limited Lifetime Warranty (*continued*)

WARRANTY CONDITIONS:

- This warranty only covers HHT appliances that are purchased through an HHT authorized dealer or distributor. A list of HHT authorized dealers is available on the HHT branded websites.
- This warranty is only valid while the HHT appliance remains at the site of original installation.
- Contact your installing dealer for warranty service. If the installing dealer is unable to provide necessary parts, contact the nearest HHT authorized dealer or supplier. Additional service fees may apply if you are seeking warranty service from a dealer other than the dealer from whom you originally purchased the product.
- Check with your dealer in advance for any costs to you when arranging a warranty call. Travel and shipping charges for parts are not covered by this warranty.

WARRANTY EXCLUSIONS:

This warranty does not cover the following:

- Changes in surface finishes as a result of normal use. As a heating appliance, some changes in color of interior and exterior surface finishes may occur. This is not a flaw and is not covered under warranty.
- Damage to printed, plated, or enameled surfaces caused by fingerprints, accidents, misuse, scratches, melted items, or other external sources and residues left on the plated surfaces from the use of abrasive cleaners or polishes.
- Repair or replacement of parts that are subject to normal wear and tear during the warranty period. These parts include: paint, wood, pellet and coal gaskets, firebricks, grates, flame guides, light bulbs, batteries and the discoloration of glass.
- Minor expansion, contraction, or movement of certain parts causing noise. These conditions are normal and complaints related to this noise are not covered by this warranty.
- Damages resulting from: (1) failure to install, operate, or maintain the appliance in accordance with the installation instructions, operating instructions, and listing agent identification label furnished with the appliance; (2) failure to install the appliance in accordance with local building codes; (3) shipping or improper handling; (4) improper operation, abuse, misuse, continued operation with damaged, corroded or failed components, accident, or improperly/incorrectly performed repairs; (5) environmental conditions, inadequate ventilation, negative pressure, or drafting caused by tightly sealed constructions, insufficient make-up air supply, or handling devices such as exhaust fans or forced air furnaces or other such causes; (6) use of fuels other than those specified in the operating instructions; (7) installation or use of components not supplied with the appliance or any other components not expressly authorized and approved by HHT; (8) modification of the appliance not expressly authorized and approved by HHT in writing; and/or (9) interruptions or fluctuations of electrical power supply to the appliance.
- Non-HHT venting components, hearth components or other accessories used in conjunction with the appliance.
- Any part of a pre-existing fireplace system in which an insert or a decorative gas appliance is installed.
- HHT's obligation under this warranty does not extend to the appliance's capability to heat the desired space. Information is provided to assist the consumer and the dealer in selecting the proper appliance for the application. Consideration must be given to appliance location and configuration, environmental conditions, insulation and air tightness of the structure.

This warranty is void if:

- The appliance has been over-fired or operated in atmospheres contaminated by chlorine, fluorine, or other damaging chemicals. Over-firing can be identified by, but not limited to, warped plates or tubes, rust colored cast iron, bubbling, cracking and discoloration of steel or enamel finishes.
- The appliance is subjected to prolonged periods of dampness or condensation.
- There is any damage to the appliance or other components due to water or weather damage which is the result of, but not limited to, improper chimney or venting installation.

LIMITATIONS OF LIABILITY:

- The owner's exclusive remedy and HHT's sole obligation under this warranty, under any other warranty, express or implied, or in contract, tort or otherwise, shall be limited to replacement, repair, or refund, as specified above. In no event will HHT be liable for any incidental or consequential damages caused by defects in the appliance. Some states do not allow exclusions or limitation of incidental or consequential damages, so these limitations may not apply to you. This warranty gives you specific rights; you may also have other rights, which vary from state to state. **EXCEPT TO THE EXTENT PROVIDED BY LAW, HHT MAKES NO EXPRESS WARRANTIES OTHER THAN THE WARRANTY SPECIFIED HEREIN. THE DURATION OF ANY IMPLIED WARRANTY IS LIMITED TO DURATION OF THE EXPRESSED WARRANTY SPECIFIED ABOVE.**

1 Listing and Code Approvals

A. Appliance Certification

MODELS: Grand-I35, Grand-I35-SP,
Supreme-I30, Supreme-I30-SP

LABORATORY: Underwriters Laboratories, Inc. (UL)

TYPE: Vented Gas Fireplace Heater

STANDARD: ANSI Z21.88-2009 CSA 2.33-2009
Vented Gas Fireplace Heaters

This product is listed to ANSI standards for “Vented Gas Appliance Heaters” and applicable sections of “Gas Burning Heating Appliances for Manufactured Homes and Recreational Vehicles”, and “Gas Fired Appliances for Use at High Altitudes”.

Heat & Glo gas inserts are designed for installations into solid fuel masonry or factory built fireplaces that have been installed in accordance with the National, Provincial, State and local building codes. Fireplaces are to be constructed of non-combustible materials and, in the absence of local or regional codes, meet criteria of NFPA 211. No additional outside air source is required.

NOTICE: This installation must conform with local codes. In the absence of local codes you must comply with the National Fuel Gas Code, ANSI Z223.1-latest edition in the U.S.A. and the CAN/CGA B149 Installation Codes in Canada.

NOT INTENDED FOR USE AS A PRIMARY HEAT SOURCE.

This appliance is tested and approved as either supplemental room heat or as a decorative appliance. It should not be factored as primary heat in residential heating calculations.

B. Glass Specifications

This appliance is equipped with 5 mm ceramic glass. Replace glass only with 5 mm ceramic glass. Please contact your dealer for replacement glass.

C. BTU Specifications

Models (U.S. or Canada)	Maximum Input BTU/h	Minimum Input BTU/h	Orifice Size (DMS)	
Supreme-I30, Supreme-I30-SP (NG)	US (0-2000 FT)	32,000	18,000	#35
	CANADA (2000-4500 FT)	28,800	16,200	#36
Grand-I35, Grand-I35-SP, (NG)	US (0-2000 FT)	35,000	18,500	#33
	CANADA (2000-4500 FT)	33,250	18,250	#34
Supreme-I30, Supreme-I30-SP (LP)	US (0-2000 FT)	31,000	15,500	#51
	CANADA (2000-4500 FT)	27,500	14,500	#52
Grand-I35, Grand-I35-SP, (LP)	US (0-2000 FT)	35,000	17,000	#50
	CANADA (2000-4500 FT)	31,000	15,500	#51

D. High Altitude Installations

NOTICE: If the heating value of the gas has been reduced, these rules do not apply. Check with your local gas utility or authorities having jurisdiction.

When installing above 2000 feet elevation:

- In the USA: Reduce input rate 4% for each 1000 feet above 2000 feet.
- In CANADA: Reduce input rate 10% for elevations between 2000 feet and 4500 feet. Above 4500 feet, consult local gas utility.

Check with your local gas utility to determine proper orifice size.

E. Non-Combustible Materials Specification

Material which will not ignite and burn. Such materials are those consisting entirely of steel, iron, brick, tile, concrete, slate, glass or plasters, or any combination thereof.

Materials that are reported as passing **ASTM E 136, Standard Test Method for Behavior of Materials in a Vertical Tube Furnace at 750 °C** and **UL763** shall be considered non-combustible materials.

F. Combustible Materials Specification

Materials made of or surfaced with wood, compressed paper, plant fibers, plastics, or other material that can ignite and burn, whether flame proofed or not, or plastered or unplastered shall be considered combustible materials.

G. Electrical Codes

NOTICE: This appliance must be electrically wired and grounded in accordance with local codes or, in the absence of local codes, with **National Electric Code ANSI/NFPA 70-latest edition** or the **Canadian Electric Code CSA C22.1**.

- A 120 VAC circuit for this product must be protected with ground-fault circuit-interrupter protection, in compliance with the applicable electrical codes, when it is installed in locations such as in bathrooms or near sinks.

A. Gas Fireplace Safety

⚠ WARNING



HOT SURFACES!

Glass and other surfaces are hot during operation AND cool down.

Hot glass will cause burns.

- DO NOT touch glass until it is cooled
- NEVER allow children to touch glass
- Keep children away

- CAREFULLY SUPERVISE children in same room as fireplace.
- Alert children and adults to hazards of high temperatures.

High temperatures may ignite clothing or other flammable materials.

- Keep clothing, furniture, draperies and other flammable materials away.

This appliance has been supplied with an integral barrier to prevent direct contact with the fixed glass panel. DO NOT operate the appliance with the barrier removed.

Contact your dealer or Hearth & Home Technologies if the barrier is not present or help is needed to properly install one.

If you expect that small children or vulnerable adults may come into contact with this fireplace, the following precautions are recommended:

- Install a physical barrier such as:
 - A decorative firescreen.
 - Adjustable safety gate.
- Install a switch lock or a wall/remote control with child protection lockout feature.

- Keep remote controls out of reach of children.
- Never leave children alone near a hot fireplace, whether operating or cooling down.
- Teach children to NEVER touch the fireplace.
- Consider not using the fireplace when children will be present.

Contact your dealer for more information, or visit: www.hpba.org/safety-information.

To prevent unintended operation when not using your fireplace for an extended period of time (summer months, vacation/trips, etc):

- Remove batteries from remote controls.
- Turn off wall controls.
- Turn off gas controls valve on standing pilot models.

When lighting the pilot light on fireplaces with a standing pilot, remove the fixed glass assembly so you can detect presence of residual gas build-up. See Standing Pilot Lighting instructions and Maintenance Tasks.

B. Your Fireplace

WARNING! DO NOT operate fireplace before reading and understanding operating instructions. Failure to operate fireplace according to operating instructions could cause fire or injury.

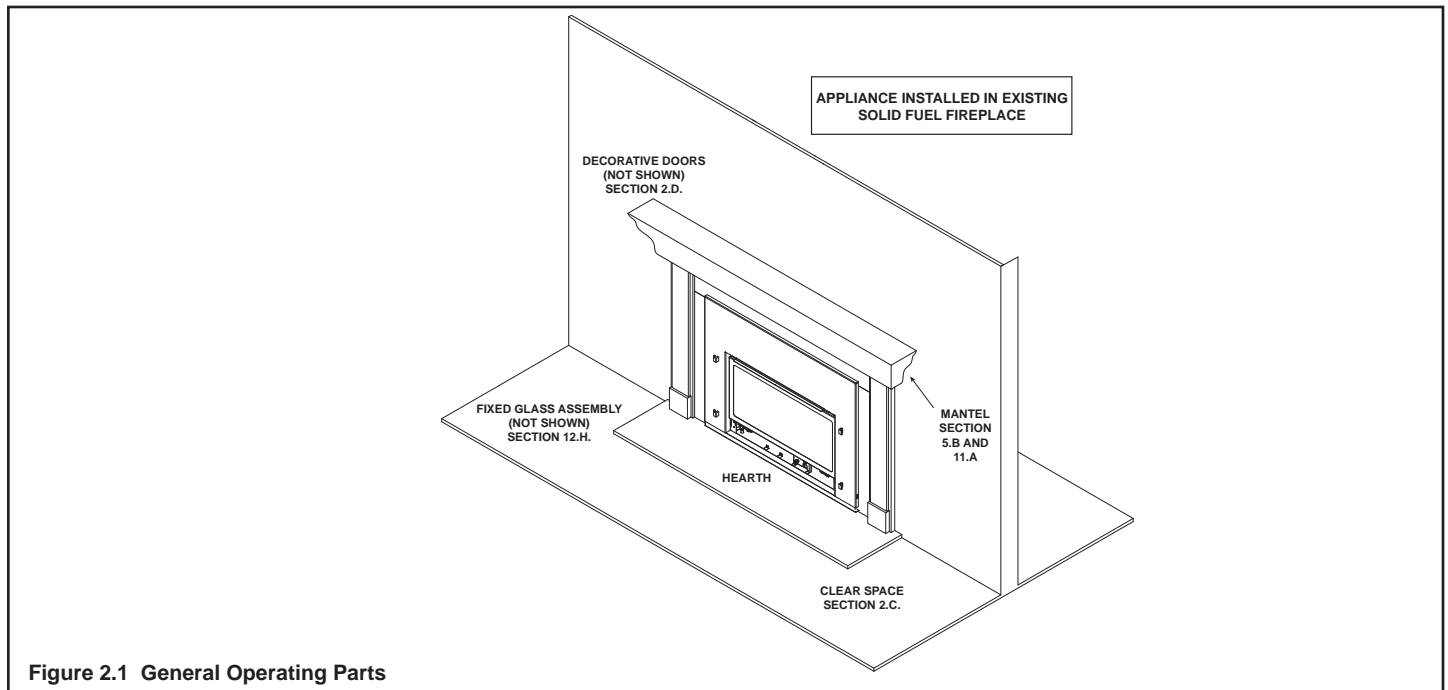

Figure 2.1 General Operating Parts

C. Clear Space

WARNING! DO NOT place combustible objects in front of the fireplace or block louvers. High temperatures may start a fire. See Figure 2.2.

Avoid placing candles and other heat-sensitive objects on mantel or hearth. Heat may damage these objects.

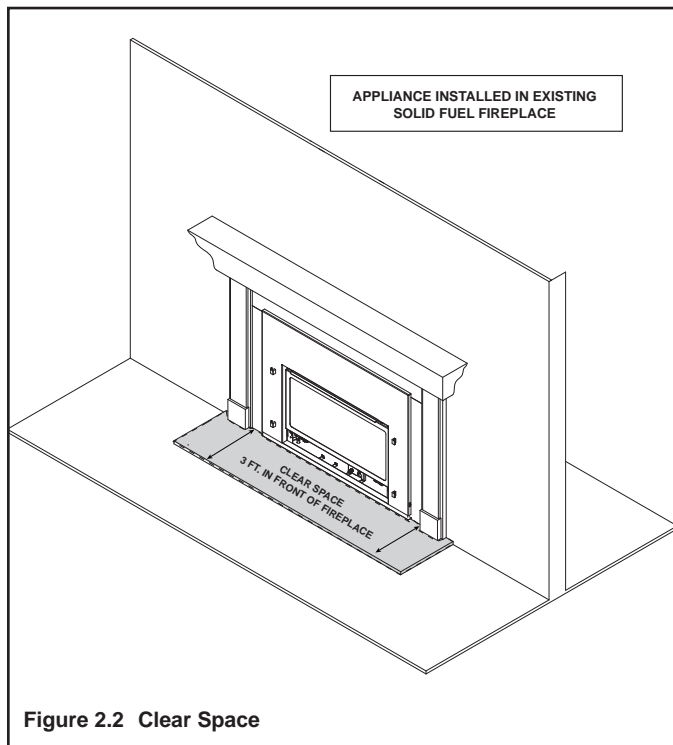

Figure 2.2 Clear Space

D. Decorative Doors, Fronts and Surrounds

WARNING! Risk of Fire! Install **ONLY** doors, fronts or surrounds approved by Hearth & Home Technologies. Unapproved doors or fronts may cause appliance to over-heat.

This appliance has been supplied with an integral barrier to prevent direct contact with the fixed glass panel. DO NOT operate the appliance with the barrier removed.

Contact your dealer or Hearth & Home Technologies if the barrier is not present or help is needed to properly install one.

For more information refer to the instructions supplied with your decorative door or front.

E. Fixed Glass Assembly

See Section 12.H.

F. Remote Controls, Wall Controls and Wall Switches

Follow the instructions supplied with the control installed to operate your fireplace:

For safety:

- Install a switch lock or a wall/remote control with child protection lockout feature.
- Keep remote controls out of reach of children.

See your dealer if you have questions.

G. IPI Battery Tray/Battery Installation

The IntelliFire Plus™ system has a battery backup option. Battery longevity and performance will be affected by the service temperatures of this appliance.

NOTICE: Batteries should only be used as a power source in the event of an emergency such as an outage.

H. Control Module Operation

1. The control module has an ON/OFF/REMOTE selector switch that must be set. See Figure 2.3.

OFF Position: Appliance will ignore all power inputs and will not respond to any commands from a wall switch or remote. The unit should be in the OFF position during installation, service, battery installation, fuel conversion, and in the event that the control goes into LOCK-OUT mode as a result of an error code.

ON Position: Appliance will ignite and run continuously in the HI flame setting, with no adjustment in flame output. This mode of operation is primarily used for initial installation or power outage operation with battery backup.

REMOTE Position: Appliance will initiate commands from an optional wired wall switch and/or the wireless remote (RC300).

2. If using a wired wall switch with the module in REMOTE mode, the flame output can be adjusted with the HI/LO selector switch on the module. See Figure 2.3. Note that the flame HI/LO selector switch will become inactive once an optional remote control (RC200/RC300) is programmed to the control module. Note that the control module will always ignite the fireplace on HI and remain so for the initial 10 seconds of operation. If the HI/LO is switched to the LO position, the flame output will automatically drop to the lowest setting after the flame has been established for 10 sec. After this 10 second period, the flame can be adjusted from HI to LO with the switch.
3. The control module has safety feature that automatically shuts down the fireplace after 9 hours of continuous operation without receiving a command from the RC300 remote.

- If you intend to use both an optional wired wall switch and the RC300 remote control to operate your fireplace, the wall switch will override any commands given by the remote.

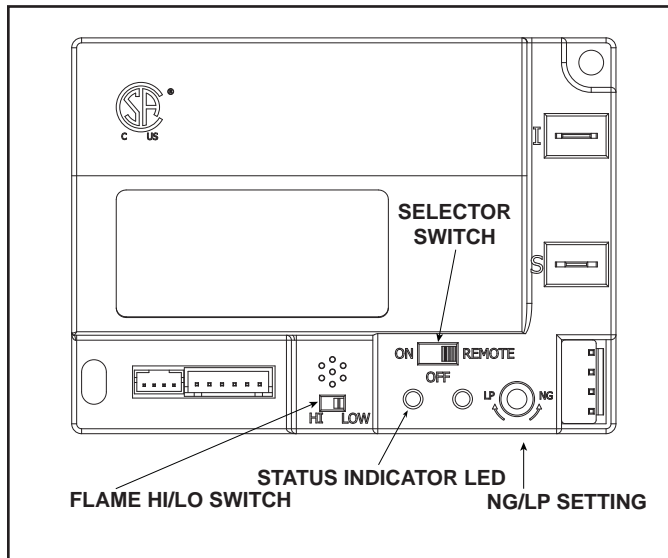

Figure 2.3 Control Module

5. Module Reset

This module may lock-out under certain conditions. When this occurs, the appliance will not ignite or respond to commands. The module will go into lock-out mode by emitting three audible beeps, then continuously displaying a RED/GREEN error code at its status indicator LED.

- Check battery tray. Remove batteries if installed. Batteries should only be installed for use during power outages. See Section G.
- Locate the module selector switch. (See Figure 2.3).
- Set the module selector switch to the OFF position.
- Wait five (5) minutes to allow possible accumulated gas to clear.
- Set the module selector switch to ON or REMOTE position.
- Start the appliance.

WARNING! Risk of Explosion! DO NOT press the module reset switch more than one time within a five minute time period. Gas may accumulate in firebox. Call a qualified service technician.

→ Nine Hour Safety Shutdown Feature

This appliance will automatically shut down after nine hours of continuous operation.

NOTICE: If the appliance shuts down after 9 hours of continuous operation, the module must be reset. See Module Reset instructions in this section.

I. Before Lighting Fireplace

Before operating this fireplace for the first time, **have a qualified technician:**

- Verify all shipping materials have been removed from inside and/or underneath the firebox.
- Review proper placement of logs, ember material and/or other decorative materials.
- Check the wiring.
- Check the air shutter adjustment.
- Ensure that there are no gas leaks.
- Ensure that the glass is sealed and in the proper position and that the integral barrier is in place.

WARNING! Risk of Fire/Asphyxiation! DO NOT operate fireplace with fixed glass assembly removed.

Determine if this fireplace has a standing pilot or an Intellifire ignition system. Ask your dealer or open control access panel, look at gas valve.

- A standing pilot ignition will have a red or black ignitor button (refer to Figure 2.4).
- An Intellifire ignition system will not have a button.

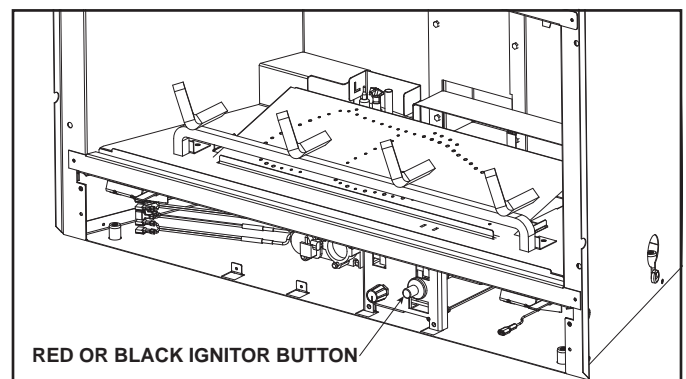

Figure 2.4 Ignitor Button

J. Lighting Instructions (IPI)

The IPI system may be operated with four AA-cell batteries. When using batteries, unplug the transformer. To prolong battery life, remove them when using the transformer.

FOR YOUR SAFETY READ BEFORE LIGHTING

WARNING: If you do not follow these instructions exactly, a fire or explosion may result causing property damage, personal injury or loss of life.

- A.** This appliance is equipped with an intermittent pilot ignition (IPI) device which automatically lights the burner. **DO NOT** try to light the burner by hand.
- Immediately call your gas supplier from a neighbor's phone. Follow the gas supplier's instructions.
 - If you cannot reach your gas supplier, call the fire department.

- B. BEFORE LIGHTING,** smell all around the appliance area for gas. Be sure to smell next to the floor because some gas is heavier than air and will settle on the floor.
- C. DO NOT** use this appliance if any part has been under water. Immediately call a qualified service technician to inspect the appliance and to replace any part of the control system and any gas control which has been under water.

WHAT TO DO IF YOU SMELL GAS

- **DO NOT** try to light any appliance.
- **DO NOT** touch any electric switch; do not use any phone in your building.

WARNING:

DO NOT CONNECT LINE VOLTAGE (110/120 VAC OR 220/240 VAC) TO THE CONTROL VALVE.

Improper installation, adjustment, alteration, service or maintenance can cause injury or property damage. Refer to the owner's information manual provided with this appliance.

This appliance needs fresh air for safe operation and must be installed so there are provisions for adequate combustion and ventilation air.

If not installed, operated, and maintained in accordance with the manufacturer's instructions, this product could expose you to substances in fuel or fuel combustion which are known to the State of California to cause cancer, birth defects, or other reproductive harm.

Keep burner and control compartment clean. See installation and operating instructions accompanying appliance.

For additional information on operating your
Hearth & Home Technologies fireplace, please refer to www.fireplaces.com.

CAUTION:

Hot while in operation. **DO NOT** touch. Keep children, clothing, furniture, gasoline and other liquids having flammable vapors away.

DO NOT operate the appliance with fixed glass assembly removed, cracked or broken. Replacement of the fixed glass assembly should be done by a licensed or qualified service person.

NOT FOR USE WITH SOLID FUEL

For use with natural gas and propane. A conversion kit, as supplied by the manufacturer, shall be used to convert this appliance to the alternate fuel.

Also Certified for Installation in a Bedroom or a Bedsitting Room.

For assistance or additional information, consult a qualified installer, service agency or the gas supplier.

LIGHTING INSTRUCTIONS (IPI)

1. This appliance is equipped with an ignition device which automatically lights the burner. **DO NOT** try to light the burner by hand.

**GAS
VALVE**

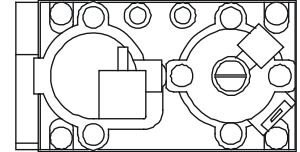

2. Wait five (5) minutes to clear out any gas. Then smell for gas, including near the floor. If you smell gas, **STOP!** Follow "B" in the Safety Information located on the left side of this label. If you do not smell gas, go to next step.

3. To light the burner:

Equipped with wall switch: Turn ON/OFF switch to ON.

Equipped with remote or wall control: Press ON or FLAME button.

Equipped with thermostat: Set temperature to desired setting.

4. If the appliance does not light after three tries, call your service technician or gas supplier.

TO TURN OFF GAS TO APPLIANCE

1. Equipped with wall switch: Turn ON/OFF switch to OFF.

Equipped with remote or wall control: Press OFF button.

Equipped with thermostat: Set temperature to lowest setting.

2. Service technician should turn off electric power to the control when performing service.

593-913G

Final inspection by _____

FOR YOUR SAFETY READ BEFORE LIGHTING

WARNING: If you do not follow these instructions exactly, a fire or explosion may result causing property damage, personal injury or loss of life.

- A. This appliance has a pilot which must be lighted by hand. When lighting the pilot, follow these instructions exactly.
- B. **BEFORE LIGHTING**, smell all around the appliance area for gas. Be sure to smell next to the floor because some gas is heavier than air and will settle on the floor.
- WHAT TO DO IF YOU SMELL GAS**
 - **DO NOT** try to light any appliance.
 - **DO NOT** touch any electric switch; do not use any phone in your building.
 - Immediately call your gas supplier from a neighbor's phone. Follow the gas supplier's instructions.
- If you cannot reach your gas supplier, call the fire department.
- C. Use only your hand to push in or turn the gas control knob. Never use tools. If the knob will not push in or turn by hand, **DO NOT** try to repair it, call a qualified service technician. Force or attempted repair may result in a fire or explosion.
- D. **DO NOT** use this appliance if any part has been under water. Immediately call a qualified service technician to inspect the appliance and to replace any part of the control system and any gas control which has been under water.

WARNING:

DO NOT CONNECT 110 VAC TO THE CONTROL VALVE.

Improper installation, adjustment, alteration, service or maintenance can cause injury or property damage. Refer to the owner's information manual provided with this appliance.

This appliance needs fresh air for safe operation and must be installed so there are provisions for adequate combustion and ventilation air.

If not installed, operated, and maintained in accordance with the manufacturer's instructions, this product could expose you to substances in fuel or fuel combustion which are known to the State of California to cause cancer, birth defects, or other reproductive harm.

Keep burner and control compartment clean. See installation and operating instructions accompanying appliance.

For additional information on operating your
Hearth & Home Technologies fireplace, please refer to www.fireplaces.com.

CAUTION:

Hot while in operation. **DO NOT** touch. Keep children, clothing, furniture, gasoline and other liquids having flammable vapors away.

DO NOT operate the appliance with fixed glass assembly removed, cracked or broken. Replacement of the fixed glass assembly should be done by a licensed or qualified service person.



NOT FOR USE WITH SOLID FUEL

For use with natural gas and propane. A conversion kit, as supplied by the manufacturer, shall be used to convert this appliance to the alternate fuel.

Also Certified for Installation in a Bedroom or a Bedsitting Room.

For assistance or additional information, consult a qualified installer, service agency or the gas supplier.

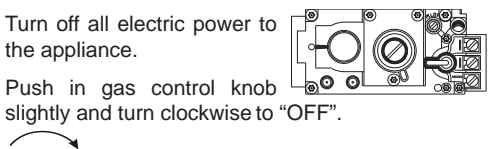
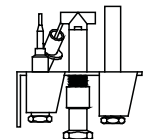
LIGHTING INSTRUCTIONS

1. Open control access panel.
2. Turn off all electric power to the appliance.
3. Push in gas control knob slightly and turn clockwise to "OFF".

- Note:** Knob cannot be turned from "PILOT" to "OFF" unless knob is pushed in slightly. **DO NOT** force.
4. Open the fixed glass assembly. You may need to remove the decorative front.
5. Wait five (5) minutes to clear out any gas. Then smell for gas, including near the floor. If you smell gas, STOP! Follow "B" in the Safety Information located on the left side of this label. If you don't smell gas, go to next step.
6. Find the pilot. The pilot is inside combustion chamber next to the main burner.

7. Turn knob on gas control counterclockwise to "PILOT".

8. Push in control knob all the way and hold in. Immediately depress red or black piezo button. It may require several depressions of the red or black piezo button until PILOT lights. If PILOT light does not light after 10 seconds, return to step 3. Continue to hold the control knob in for about one minute after the pilot is lit. Release knob and it will pop back out. Pilot should remain lit. If it goes out, repeat steps 3 through 6.
 - If knob does not pop up when released, stop and immediately call your service technician or gas supplier.
 - If the pilot will not stay lit after several tries, turn the gas control knob to "OFF" and call your service technician or gas supplier.
9. Reinstall fixed glass assembly. Reinstall decorative front.
10. Turn gas control knob counterclockwise to "ON". Close access panel.

11. Turn on all electric power to the appliance.
12. To light burner, turn the wall control or on/off switch to "ON".

TO TURN OFF GAS TO APPLIANCE

1. Turn off all electric power to the appliance if service is to be performed.
2. Open control access panel.
3. Move switch to "OFF" position.
4. Push in gas control knob slightly and turn clockwise to "OFF". **DO NOT** force.

5. Close control access panel.

Final inspection by _____

K. After Appliance is Lit

Initial Break-in Procedure

- The appliance should be run three to four hours continuously on high.
- Turn the appliance off and allow it to completely cool.
- Remove fixed glass assembly. See Section 12.H.
- Clean fixed glass assembly. See Section 3.
- Replace the fixed glass assembly and run continuously on high an additional 9 hours.

This cures the materials used to manufacture the fireplace.

NOTICE! Open windows for air circulation during appliance break-in.

- *Some people may be sensitive to smoke and odors.*
- *Smoke detectors may activate.*

L. Frequently Asked Questions

ISSUE	SOLUTIONS
Condensation on the glass	This is a result of gas combustion and temperature variations. As the appliance warms, this condensation will disappear.
Blue flames	This is a result of normal operation and the flames will begin to yellow as the appliance is allowed to burn for 20 to 40 minutes.
Odor from appliance	When first operated, this appliance may release an odor for the first several hours. This is caused by the curing of the paint and the burning off of any oils remaining from manufacturing. Odor may also be released from finishing materials and adhesives used around the appliance.
Film on the glass	This is a normal result of the curing process of the paint and logs. Glass should be cleaned within 3 to 4 hours of initial burning to remove deposits left by oils from the manufacturing process. A non-abrasive cleaner such as gas fireplace glass cleaner may be necessary. See your dealer.
Metallic noise	Noise is caused by metal expanding and contracting as it heats up and cools down, similar to the sound produced by a furnace or heating duct. This noise does not affect the operation or longevity of the appliance.
Is it normal to see the pilot flame burn continually?	In an intermittent pilot ignition system (IPI), the pilot flame should turn off when appliance is turned off. Some optional control systems available with IPI models may allow pilot flame to remain lit. In a standing pilot system the pilot will always stay on.

3 Maintenance and Service

Any safety screen or guard removed for servicing must be replaced prior to operating the appliance.

When properly maintained, your appliance will give you many years of trouble-free service. We recommend annual service by a qualified technician.

A. Maintenance Tasks-Homeowner

Installation and repair should be done by a qualified technician only. The appliance should be inspected before use and at least annually by a professional service person.

The following tasks may be performed annually by the homeowner. If you are uncomfortable performing any of the listed tasks, please call your dealer for a service appointment.

More frequent cleaning may be required due to lint from carpeting or other factors. Control compartment, burner and circulating air passageway of the appliance must be kept clean.

CAUTION! Risk of Burns! The appliance should be turned off and cooled before servicing.

Glass Cleaning

Frequency: Seasonally

By: Homeowner

Tools Needed: Protective gloves, glass cleaner, drop cloth and a stable work surface.

CAUTION! Handle fixed glass assembly with care. Glass is breakable.

- Avoid striking, scratching or slamming glass
 - Avoid abrasive cleaners
 - **DO NOT** clean glass while it is hot
 - Prepare a work area large enough to accommodate fixed glass assembly and door frame by placing a drop cloth on a flat, stable surface.
- Note:** Fixed glass assembly and gasketing may have residue that can stain carpeting or floor surfaces.
- Remove door or decorative front from appliance and set aside on work surface.
 - See Section 12.H for instructions to remove fixed glass assembly.
 - Clean glass with a non-abrasive commercially available cleaner.
 - Light deposits: Use a soft cloth with soap and water
 - Heavy deposits: Use commercial fireplace glass cleaner (consult with your dealer)
 - Carefully set fixed glass assembly in place on appliance. Hold glass in place with one hand and secure glass latches with the other hand.
 - Reinstall door or decorative front.

Doors, Surrounds, Fronts

Frequency: Annually

By: Homeowner

Tools needed: Protective gloves, stable work surface

- Assess condition of screen and replace as necessary.
- Inspect for scratches, dents or other damage and repair as necessary.
- Check that louvers are not blocked.
- Vacuum or dust surfaces.

Remote Control

Frequency: Seasonally

By: Homeowner

Tools needed: Replacement batteries and remote control instructions.

- Locate remote control transmitter and receiver.
- Verify operation of remote. Refer to remote control operation instructions for proper calibration and setup procedure.
- Place batteries as needed in remote transmitters and battery-powered receivers.
- Place remote control out of reach of children.

If not using your fireplace for an extended period of time (summer months, vacations/trips, etc), to prevent unintended operation:

- Remove batteries from remote controls.

Venting

Frequency: Seasonally

By: Homeowner

Tools needed: Protective gloves and safety glasses.

- Inspect venting and termination cap for blockage or obstruction such plants, bird nests, leaves, snow, debris, etc.
- Verify termination cap clearance to subsequent construction (building additions, decks, fences, or sheds). See Section 6.
- Inspect for corrosion or separation.
- Verify weather stripping, sealing and flashing remains intact.
- Inspect draft shield to verify it is not damaged or missing.

B. Maintenance Tasks-Service Technician

The following tasks must be performed by a qualified technician.

Gasket Seal and Glass Assembly Inspection

Frequency: Annually

By: Service Technician

Tools needed: Protective gloves, drop cloth and a stable work surface.

- Inspect gasket seal and its condition.
- Inspect fixed glass assembly for scratches and nicks that can lead to breakage when exposed to heat.
- Confirm there is no damage to glass or glass frame. Replace as necessary.
- Verify that fixed glass assembly is properly retained and attachment components are intact and not damaged. Replace as necessary.

Logs

Frequency: Annually

By: Service Technician

Tools needed: Protective gloves.

- Inspect for damaged or missing logs. Replace as necessary. Refer to Section 12 for log placement instructions.
- Verify correct log placement and no flame impingement causing sooting. Correct as necessary.

Firebox

Frequency: Annually

By: Service Technician

Tools needed: Protective gloves, sandpaper, steel wool, cloths, mineral spirits, primer and touch-up paint.

- Inspect for paint condition, warped surfaces, corrosion or perforation. Sand and repaint as necessary.
- Replace appliance if firebox has been perforated.

Control Compartment and Firebox Top

Frequency: Annually

By: Service Technician

Tools needed: Protective gloves, vacuum cleaner, dust cloths

- Vacuum and wipe out dust, cobwebs, debris or pet hair. Use caution when cleaning these areas. Screw tips that have penetrated the sheet metal are sharp and should be avoided.
- Remove all foreign objects.
- Verify unobstructed air circulation.

Burner Ignition and Operation

Frequency: Annually

By: Service Technician

Tools needed: Protective gloves, vacuum cleaner, whisk broom, flashlight, voltmeter, indexed drill bit set, and a manometer.

- Verify burner is properly secured and aligned with pilot or igniter.
- Clean off burner top, inspect for plugged ports, corrosion or deterioration. Replace burner if necessary.
- Replace Glowing embers with new dime-size pieces. **DO NOT** block ports or obstruct lighting paths. Refer to Section 12 for proper ember placement.
- Verify batteries have been removed from battery back-up IPI systems to prevent premature battery failure or leaking. For optimal battery life, locate the battery pack outside of the control cavity on the hearth. This placement will reduce the chances of overheating the batteries during extended burns which could result in reduced battery life or degradation.
- Check for smooth lighting and ignition carryover to all ports. Verify that there is no ignition delay.
- Inspect for lifting or other flame problems.
- Verify air shutter setting is correct. See Section 12 for required air shutter setting. Verify air shutter is clear of dust and debris.
- Inspect orifice for soot, dirt and corrosion. Verify orifice size is correct. See Service Parts List for proper orifice sizing.
- Verify manifold and inlet pressures. Adjust regulator as required.
- Inspect pilot flame pattern and strength. See Figure 3.1 and 3.2 for proper pilot flame pattern. Clean or replace orifice spud as necessary.
- Inspect thermocouple/thermopile or IPI flame sensing rod for soot, corrosion and deterioration. Clean with emery cloth or replace as required.
- Verify thermocouple/thermopile millivolt output. Replace pilot as necessary. (Standing pilot only)
- Verify that there is not a short in flame sense circuit by checking continuity between pilot hood and flame sense rod. Replace pilot as necessary. (IPI only)



Figure 3.1 Standing Pilot Flame Patterns



Figure 3.2 IPI Pilot Flame Patterns

4 Getting Started

Installer Guide

A. Typical Appliance System

NOTICE: Illustrations and photos reflect typical installations and are for design purposes only. Illustrations/diagrams are not drawn to scale. Actual product may vary from pictures in manual

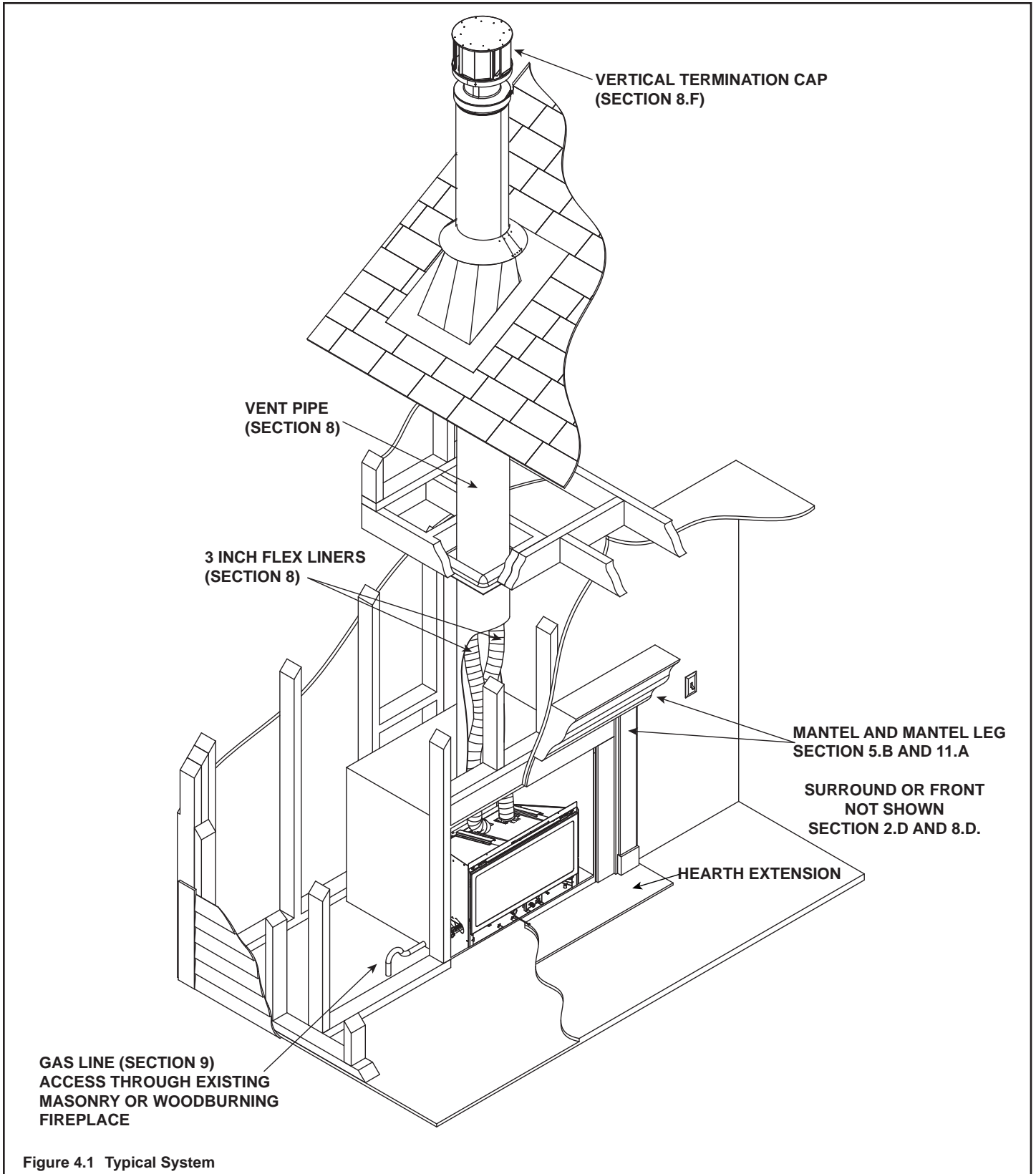

Figure 4.1 Typical System

B. Design and Installation Considerations

Heat & Glo gas inserts are designed for installations into solid fuel masonry or factory built fireplaces that have been installed in accordance with the National, Provincial, State and local building codes. Fireplaces are to be constructed of non-combustible materials and, in the absence of local or regional codes, meet criteria of NFPA 211. No additional outside air source is required.

Installation MUST comply with local, regional, state and national codes and regulations. Consult insurance carrier, local building inspector, fire officials or authorities having jurisdiction over restrictions, installation inspection and permits.

Prior to installing the gas insert:

- Have the chimney and adjacent structure inspected and cleaned by qualified professionals. Hearth & Home Technologies recommends that NFI or CSIA certified professionals, or technicians under the direction of certified professionals, conduct a minimum of a NFPA 211 Level 2 inspection of the chimney.
- Replace component parts of the chimney and fireplace as specified by the professionals.
- Ensure combustible mantel and surround clearances comply with applicable codes and regulations for solid-fuel fireplaces. In the absence of local or regional codes, refer to NFPA 211.
- Ensure all joints are properly engaged and the chimney is properly secured.
- Minimum fireplace size. See Section 5.A.
- Gas supply piping requirements.
- Electrical wiring requirements.
- Finishing details.
- Whether optional accessories—devices such as a wall switch or remote control—are desired.

Improper installation, adjustment, alteration, service or maintenance can cause injury or property damage. For assistance or additional information, consult a qualified technician, service agency or your dealer.

C. Tools and Supplies Needed

Before beginning the installation be sure that the following tools and building supplies are available.

Tape measure	Framing material
Pliers	Flat blade screwdriver
Hammer	Phillips screwdriver
Gloves	Framing square
Voltmeter	Electric drill and bits (1/4 in.)
Plumb line	Safety glasses
Level	Reciprocating saw
Manometer	Noncorrosive leak check solution
1/2 - 3/4 inch length, #6 or #8 Self-drilling screws	
Caulking material (300°F minimum continuous exposure rating)	
Stove cement (1200°F or higher continuous exposure rating)	

D. Inspect Appliance and Components

- Carefully remove the appliance and components from the packaging.
- The vent system components and decorative doors and fronts may be shipped in separate packages.
- If packaged separately, the log set and appliance grate must be installed.
- Report to your dealer any parts damaged in shipment, particularly the condition of the glass.
- **Read all of the instructions before starting the installation. Follow these instructions carefully during the installation to ensure maximum safety and benefit.**

WARNING! Risk of Fire or Explosion! Damaged parts could impair safe operation. **DO NOT** install damaged, incomplete or substitute components. Keep appliance dry.

Hearth & Home Technologies disclaims any responsibility for, and the warranty will be voided by, the following actions:

- Installation and use of any damaged appliance or vent system component.
- Modification of the appliance or vent system.
- Installation other than as instructed by Hearth & Home Technologies.
- Improper positioning of the gas logs or the glass door.
- Installation and/or use of any component part not approved by Hearth & Home Technologies.

Any such action may cause a fire hazard.

WARNING! Risk of Fire,/Explosion/Electric Shock! **DO NOT** use this appliance if any part has been under water. Call a qualified technician to inspect the appliance and to replace any part of the control system and/or gas control which has been under water.

5 Fireplace Size Requirements

A. Minimum Fireplace Opening

Minimum fireplace opening requirements for a standard 3/4 inch deep surround are shown in Figure 5.1. For smaller openings, an optional 1-1/2 inch deep surround is available and dimensions are shown in Figure 5.2.

WARNING! Risk of Fire or Burns! Provide adequate clearance around air openings and for service access. **Due to high temperatures, the appliance should be located out of traffic and away from furniture and draperies.**

- The firebrick (refractory), glass doors, screen rails, screen mesh and log grates can be removed from a factory built firebox in order to gain minimum gas insert opening requirements.
- Any smoke shelves, shields and baffles may be removed

from the factory built firebox if attached with mechanical fasteners.

- The metal floor of the solid fuel firebox may be removed to facilitate the installation of the insert. The appliance may not be placed directly on the base of the outer wrap, a 1/4 inch airspace must be provided between the insert and the floor of the outer wrap. Use the levelling legs to raise the insert a minimum of 1/4 inch. The original fireplace may never be returned to solid fuel in this condition. The sidewalls and top structure of the firebox may not be altered with the exception of removable baffles and dampers.
- Cutting of any sheet metal parts of the fireplace in which the gas fireplace insert is to be installed is prohibited, except the floor as tested for and as noted above.

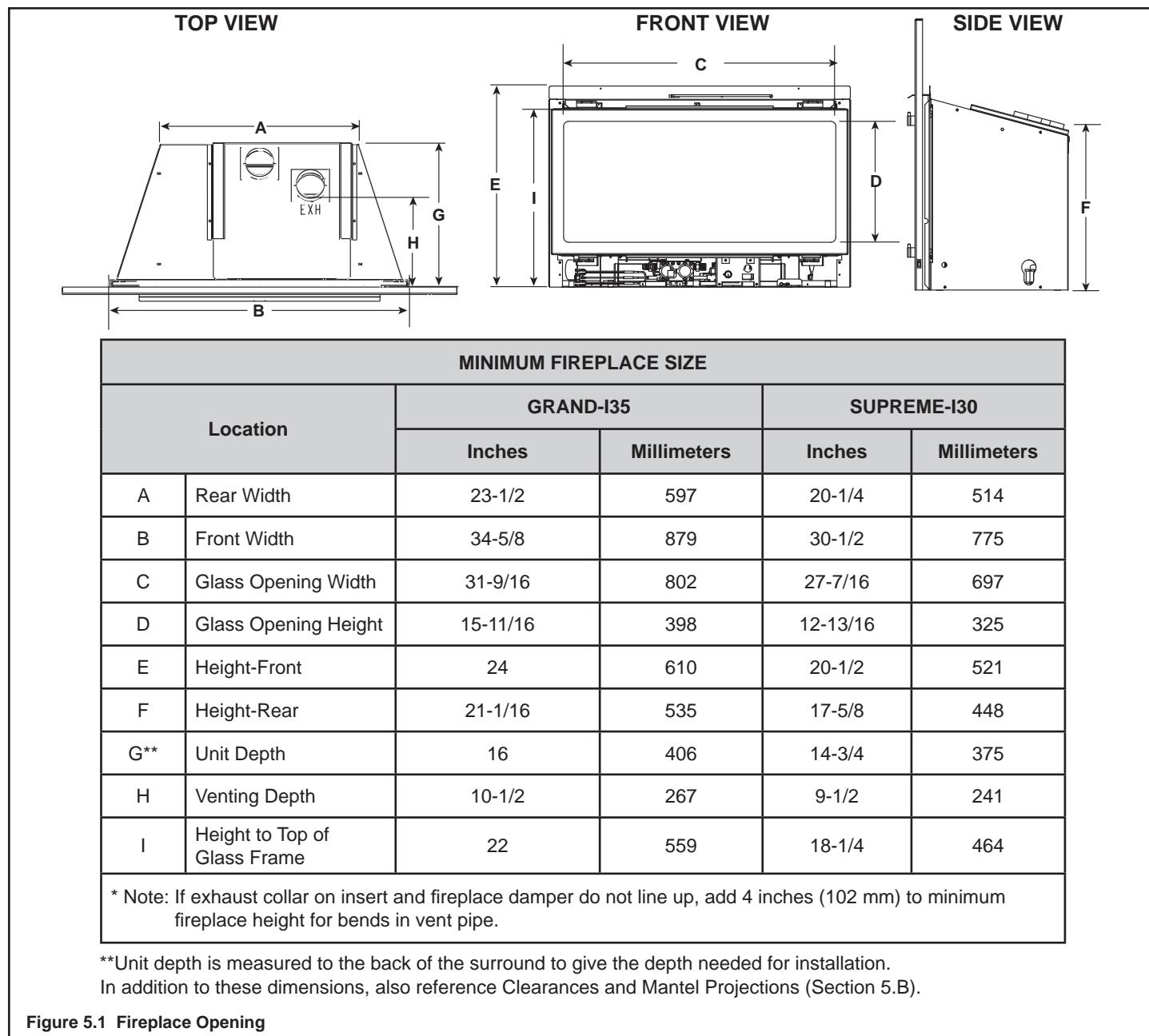

Figure 5.1 Fireplace Opening

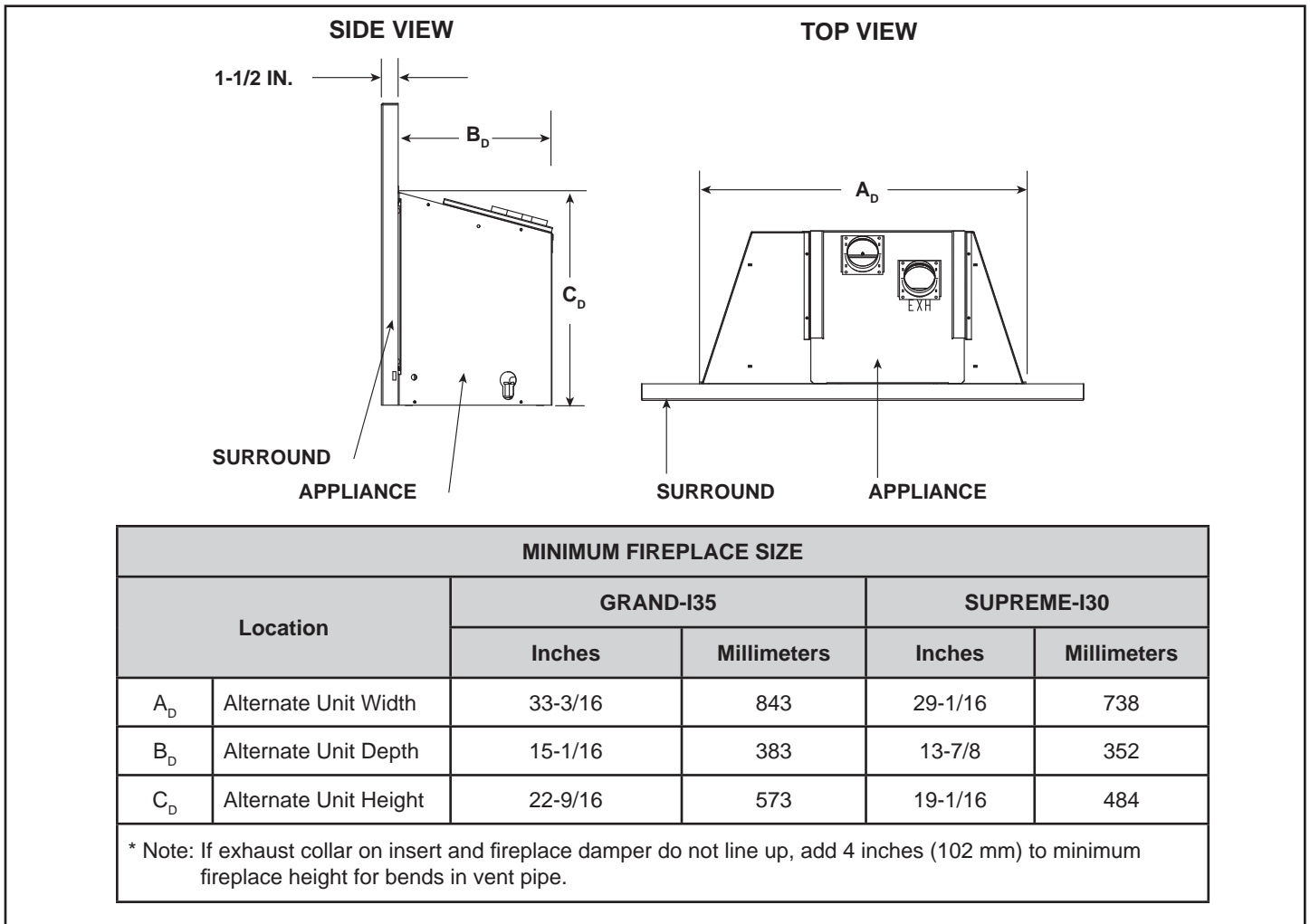

Figure 5.2 Fireplace Opening - Deep Surround

B. Mantel and Wall Projections

WARNING! Risk of Fire! Comply with all minimum clearances to combustibles as specified. Framing or finishing material closer than the minimums listed must be constructed entirely of noncombustible materials (i.e., steel studs, concrete board, etc).

Clearance to combustible material under the insert is 1/4 inch (6 mm). Clearance from top of fireplace opening for combustibles extending 12 inches max. is 12 inches.

- Use leveling legs to raise insert minimum 1/4 inch (6 mm) above combustible material or outer wrap of factory built firebox.

Combustible facings must not extend behind the insert surround. For non-combustible material specifications refer to section 1.E.

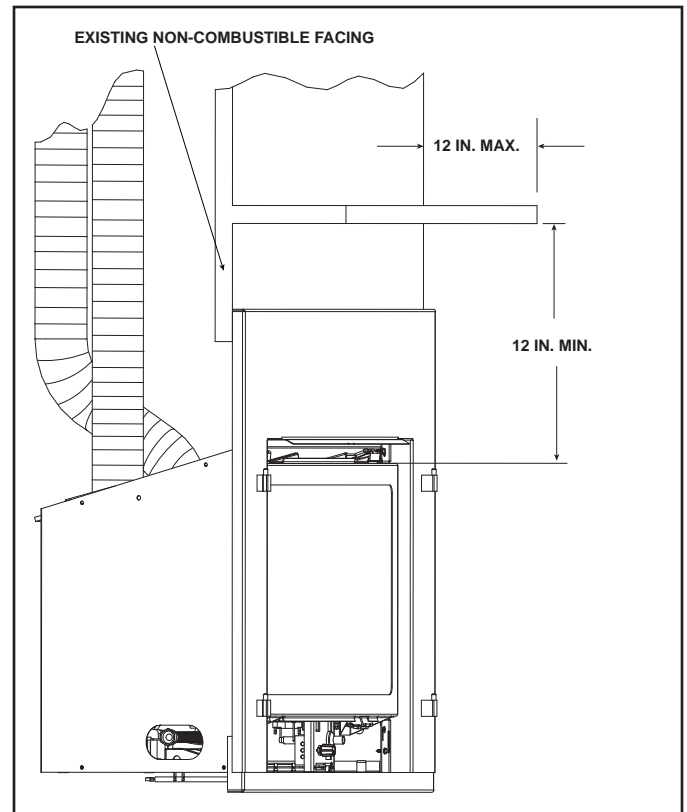

Figure 5.3 Mantel Clearances

6 Termination Locations

A. Vent Termination Minimum Clearances

⚠ WARNING

Fire Risk.
Maintain vent clearance to combustibles as specified.

- **DO NOT** pack air space with insulation or other materials.

Failure to keep insulation or other materials away from vent pipe may cause fire.

Roof Pitch	H (Min.) Ft.
Flat to 6/12.....	1.0*
Over 6/12 to 7/12.....	1.25*
Over 7/12 to 8/12.....	1.5*
Over 8/12 to 9/12.....	2.0*
Over 9/12 to 10/12.....	2.5
Over 10/12 to 11/12.....	3.25
Over 11/12 to 12/12.....	4.0
Over 12/12 to 14/12.....	5.0
Over 14/12 to 16/12.....	6.0
Over 16/12 to 18/12.....	7.0
Over 18/12 to 20/12.....	7.5
Over 20/12 to 21/12.....	8.0

* 3 foot minimum in snow regions

Figure 6.1 Minimum Height From Roof To Lowest Discharge Opening

A	B
6 in. (minimum) up to 20 in. <i>152 mm/508 mm</i>	18 in. minimum <i>457 mm</i>
20 in. and over	0 in. minimum

* If using decorative cap cover(s), this distance may need to be increased. Refer to the installation instructions supplied with the decorative cap cover.

** In a staggered installation with both gas and wood or fuel oil terminations, the wood or fuel oil termination cap must be higher than the gas termination cap.

Figure 6.2 Staggered Termination Caps

7 Installation Preparation

Prepare the existing solid fuel masonry or factory built non-combustible firebox for installation.

A. Inspection and Cleaning

Prior to installing the gas insert:

- Have the chimney and adjacent structure inspected and cleaned by qualified professionals. Hearth & Home Technologies recommends that NFI or CSIA certified professionals, or technicians under the direction of certified professionals, conduct a minimum of a NFPA 211 Level 2 inspection of the chimney.
- Replace component parts of the chimney and fireplace as specified by the professionals.
- Ensure all joints are properly engaged and the chimney is properly secured.
- Ensure combustible mantel and surround clearances comply with applicable codes and regulations for solid-fuel fireplaces. In the absence of local or regional codes, refer to NFPA 211.
- Ensure chimney is constructed of non-combustible materials.
- Ensure chimney is clean and in good working order.
- Ensure that all chimney cleanouts fit properly to prevent air leakage into chimney.

B. Flue Damper

Fully lock the solid fuel fireplace's flue damper in the open position, OR completely remove it.

C. Gas Line

Note: If the factory built fireplace has no gas access hole provided, an access hole of 1 inch (25 mm) diameter or less may be drilled through the lower sides or bottom of the firebox in a proper workmanship - like manner. This access hole must be plugged with non-combustible insulation after the gas supply line has been installed.

- Install gas line into firebox cavity.
- Check local codes and gas line sizing requirements following NFPA51. See Section 9.
- It is recommended that extra length of gas line be installed within the existing wood burner or masonry fireplace to allow removal of the insert for future servicing needs.

D. Fireplace Conversion Notice

Permanently attach the label with the following warning to the inside lower back of the fireplace firebox into which the insert is being installed. Silicone or mechanical fasteners may be required to properly secure the label.

WARNING! Risk of Fire! *This fireplace has been converted for use with a gas fireplace insert only and cannot be used for burning wood or solid fuels unless all original parts have been replaced, and the fireplace re-approved by the authority having jurisdiction.*

E. Electrical Outlet Box

An outlet box may be installed in a bottom back corner of the existing solid fuel masonry or factory built fireplace to power the appliance. Each unit ships standard with a cord assembly to permit blowers or other optional accessories to be used. The accessories plug into the new outlet box or may be routed out onto the hearth to a nearby outlet.

8 Installing Vent Pipe and Appliance

A. Vent Limits

The abbreviations listed in this vent table key are used in the vent diagrams.

Description
Minimum Vertical Run Length 10 ft.
Maximum Vertical Run Length 50 ft.

Horizontal venting is NOT allowed.

Vertical terminations are measured to top of chimney.

This appliance is listed for use with LINK-DV systems and components only. It is permissible to extend venting above existing chimney (within specified maximum vertical limits) using SL-D series or Dura Vent GS series 4 in. x 6-5/8 in. gas direct-vent pipe. Connection is made using DV-46DVA-GK. The vent must be terminated with the cap supplied with the LINK-series vent kit.

WARNING! Risk of Fire/Explosion/Asphyxiation! Do NOT connect this gas appliance to a chimney flue serving a separate solid fuel or gas burning appliance.

- May impair safe operation of this appliance or other appliances connected to the flue.
- Vent this appliance directly outside.
- Use separate vent system for this appliance.

CAUTION! ALL vent specifications MUST be followed. This product is tested and listed to these specifications. Appliance performance will suffer if specifications are not followed.

B. Venting Components

CAUTION! Risk of Cuts/Abrasions/Flying Debris. Wear protective gloves and safety glasses during installation. Sheet metal edges are sharp.

The vertical vent termination system installed on this model includes:

- Flexible vent pipe for exhaust air (included with vent kit).
- One length of 3-inch flexible vent pipe for combustion air (included with vent kit).
- One pipe-to-cap adaptor (included with vent kit).
- One vertical termination cap (included with vent kit).

C. Connecting Vent Pipe

Reference instructions in the termination kit.

- Install the 3-inch flexible vent pipe(s) down through the chimney.
- Secure the exhaust flexible vent pipe to the exhaust starting collar on top of the appliance with three screws and seal with stove cement rated for continuous exposure to 1200°F or higher. See Figure 8.1.
- Use 3 screws to attach the section of inlet air vent to the inlet collar on the collar slide plate and seal with stove cement rated for continuous exposure to 1200°F or higher. See Figure 8.1. NOTE: The collar slide plate may be removed from appliance to aid installation.

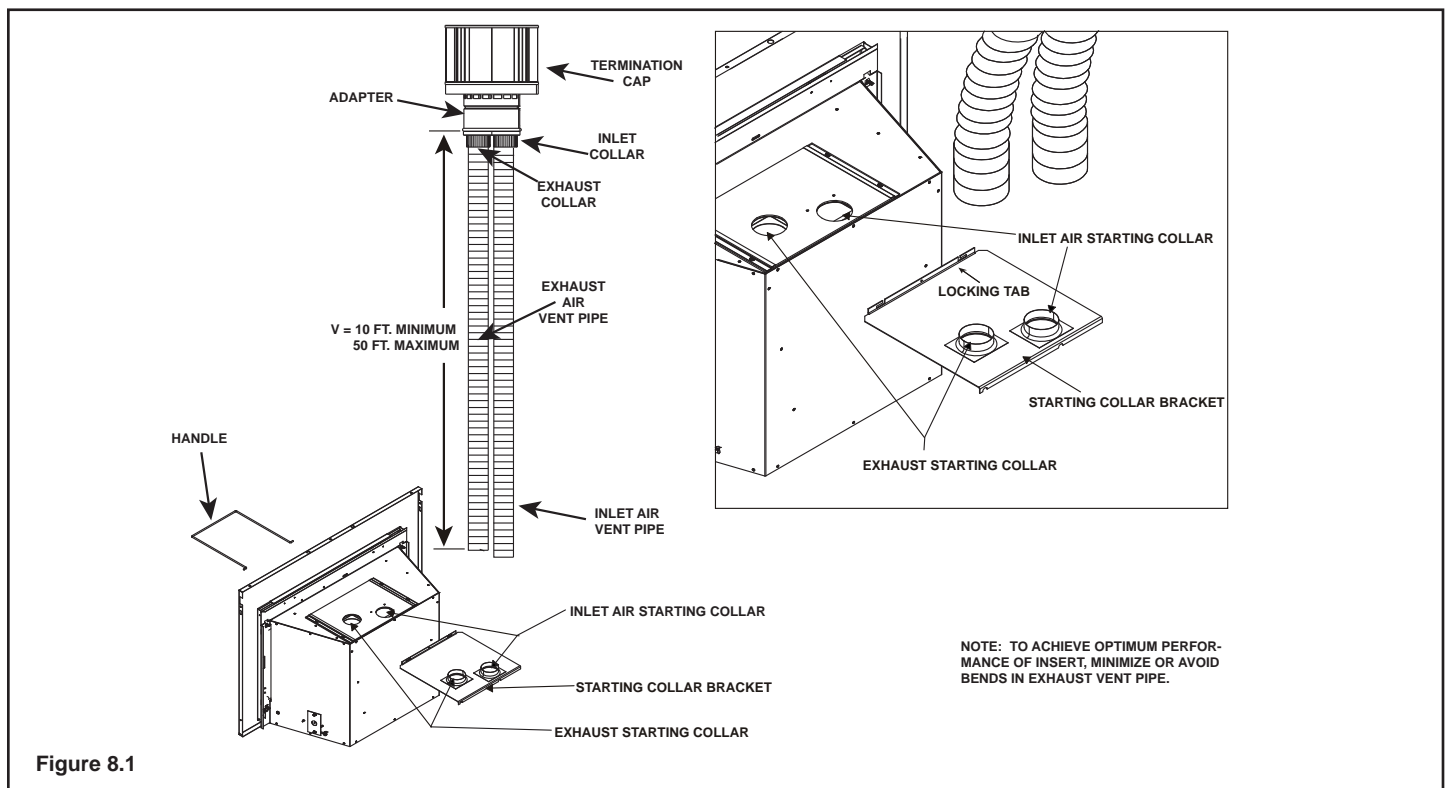

Figure 8.1

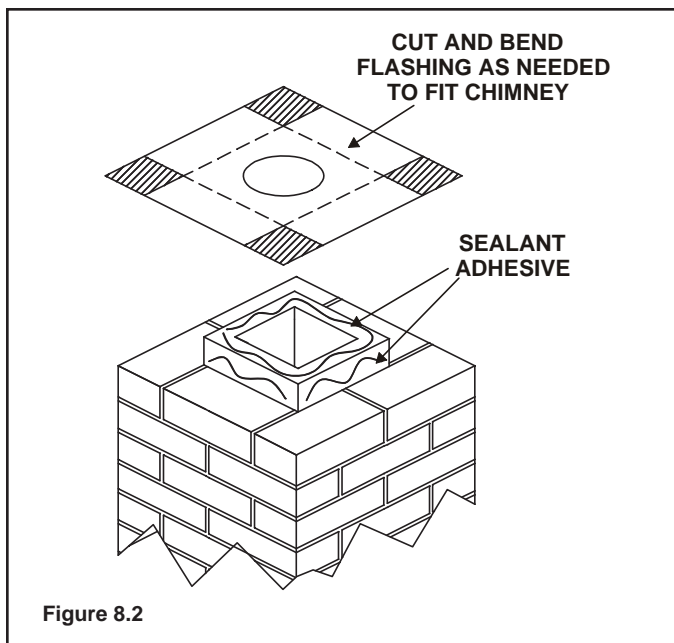

Figure 8.2

- Trim chimney top plate to minimize excess overhang or bend over flue tile (see Figure 8.2).
- Place 3/8 inch bead of 300° F silicone on flue tile top.

D. Placing, Securing and Leveling the Appliance

- Install insert (without surround attached) into existing fireplace while pulling collar slide plate forward.
- Install gas line into hole provided on insert side.
- If applicable install remote control wires into insert side (see Section 8..).
- Secure collar slide plate to appliance by placing locking handle into position with locking tabs (see Figure 8.1) and secure with #8 screw.
- Level the appliance from side to side and front to back. If necessary, use the leveling legs included with the manual bag to set each corner of the base.
- Position any excess flexible vent pipe back up into chimney without sagging. Twist and push flex vent together to shorten.
- Install fiberglass insulation pieces to back face of surround.
- Attach surround. Follow instructions for surround installation included with the front.
- Push insert into the opening so that it tightly overlaps the fireplace opening.

WARNING! Risk of Fire! Only an approved Hearth & Home Technologies surround may be used to cover integral grills on solid fuel burning fireplaces. No other components such as shrouds, sheetmetal plates, etc., may be used to seal off vents.

WARNING! Risk of Explosion! Failure to position the parts in accordance with these diagrams or failure to use only parts specifically approved with this appliance may result in property damage or personal injury.

WARNING! Risk of Explosion/Combustion Fumes! Connect vent sections per installation instructions.

- Connect exhaust vent pipe **ONLY** to exhaust starting collar and termination cap center collar.
- Connect inlet air vent **ONLY** to inlet air collar on appliance and the termination cap inlet air collar.
- **DO NOT** allow vent to sag below connection point to appliance.

E. Remote Control

Standing Pilot Models:

The receiver for the remotes may be installed between the base pan of the insert and the firebox of the wood-burning fireplace or in the control cavity of the insert. See Figure 8.3.

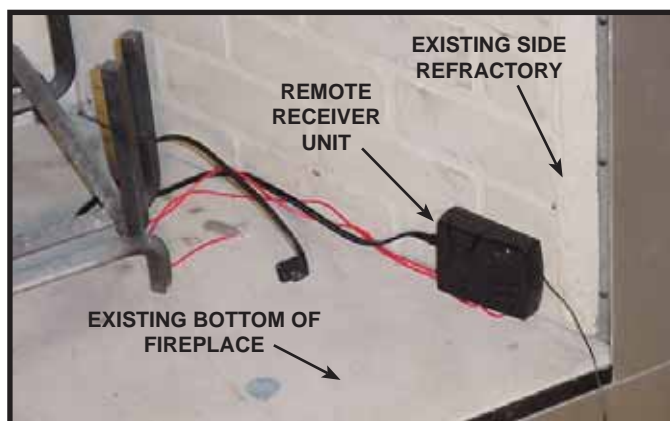

Figure 8.3 Location of Remote Receiver - Standing Pilot

IPI Models:

If a remote control kit is used to control blower function, the Auxiliary 300 module can only be placed in the control cavity to the right of the control panel. See Figure 8.4.

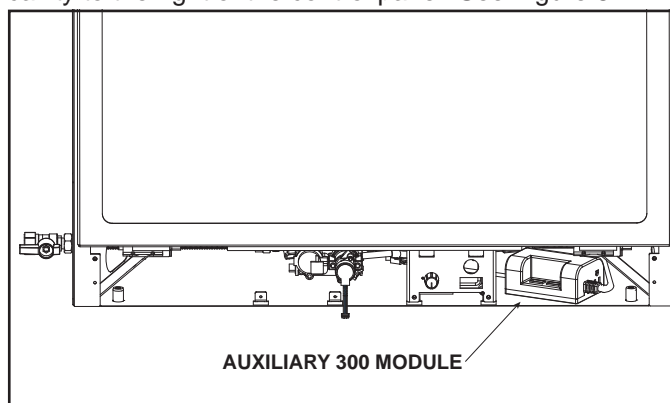
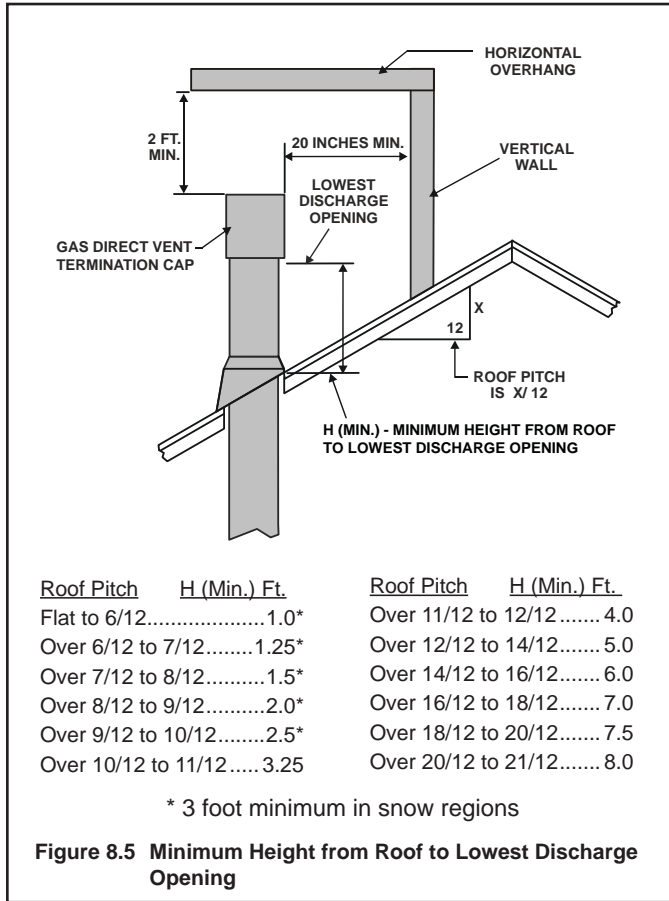

Figure 8.4 Location of AUX300 for Remote Control Blower Function - IPI

F. Installing Adaptor and Termination Cap

For installation of termination cap see minimum vent heights for various pitched roofs (see Figure 8.5) .

To install adaptor see Figure 8.6.



CAUTION! Risk of Cuts/Abrasions/Flying Debris. Wear protective gloves and safety glasses during installation. Sheet metal edges are sharp.

Damper Flashing Kit (Optional)

For use with LINK-DV30B or LINK-DV4-30B Liner Kit.

Note: Damper may have to be removed to use this kit.

- Run flex liners through 3 in. holes in damper flashing.
- Attach damper flashing to firebox roof with self tapping screws included in kit.

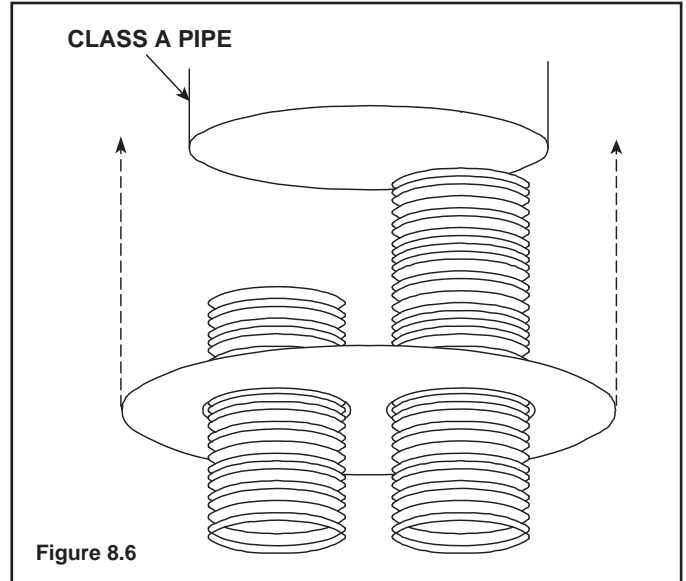

To prevent odors and cold drafts, the chimney must be sealed around the vent with non-combustible blanket insulation or field fabricated metal plates.

Note: The LINK-DV4-30B system **REQUIRES** this insulation.

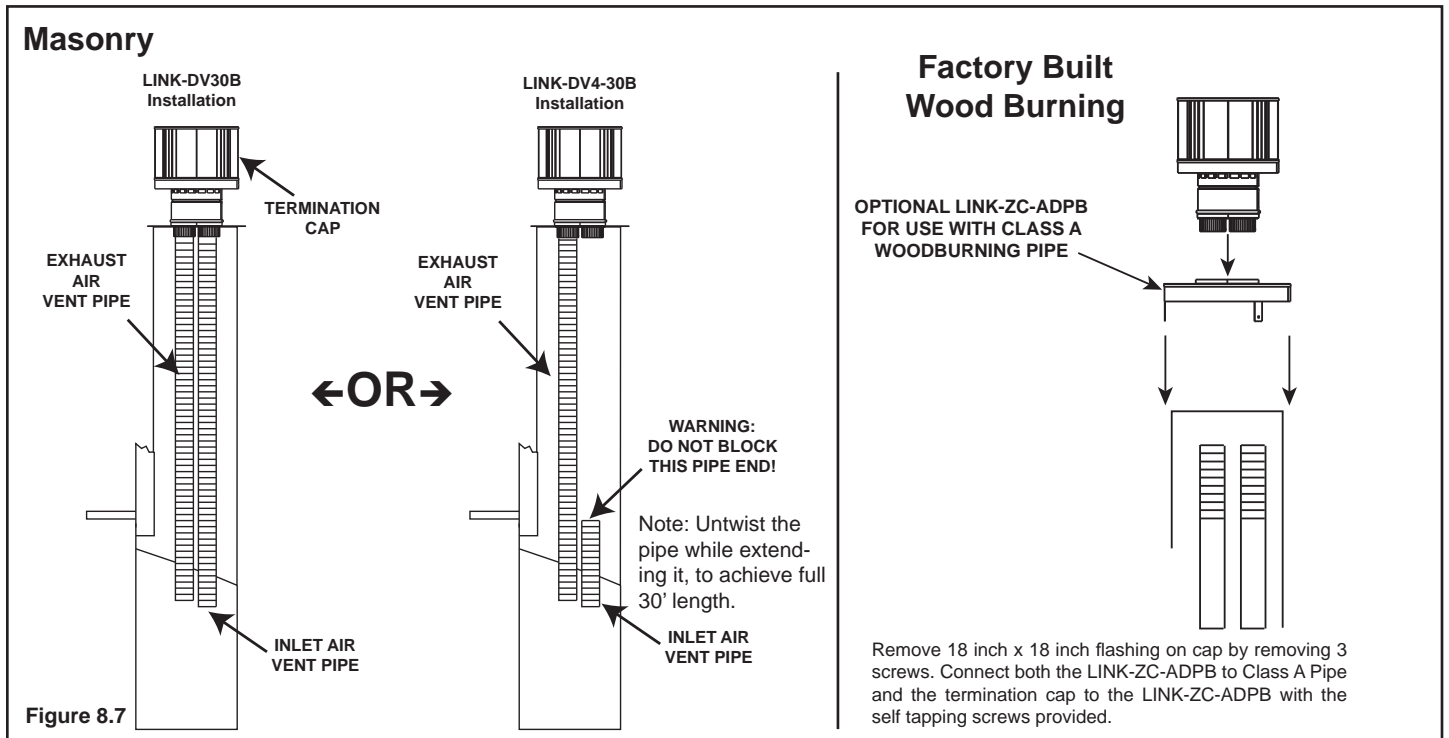

9 Gas Information

A. Fuel Conversion

- Make sure the appliance is compatible with available gas types.
- Conversions must be made by a qualified technician (NFI certified or factory-trained) using Hearth & Home Technologies specified and approved parts.

B. Gas Pressure

- Optimum appliance performance requires proper input pressures.
- Gas line sizing requirements will be determined in ANSI Z223.1 National Fuel Gas Code in the USA and CAN/CGA B149 in Canada.
- Pressure requirements are:

Gas Pressure	Natural Gas	Propane
Minimum inlet pressure	5.0 in. w.c.	11.0 in. w.c.
Maximum inlet pressure	10.0 in. w.c.	13.0 in. w.c.
Manifold pressure	3.5 in. w.c.	10.0 in. w.c.

WARNING! Risk of Fire/Explosion! High pressure will damage valve. Low pressure may cause explosion.

- Verify inlet pressures. Verify minimum pressures when other household gas appliances are operating.
- Install regulator upstream of valve if line pressure is greater than 1/2 psig.

⚠ WARNING



Fire Risk.
Explosion Hazard.
High pressure will damage valve.

- Disconnect gas supply piping **BEFORE** pressure testing gas line at test pressures above 1/2 psig.
- Close the manual shutoff valve **BEFORE** pressure testing gas line at test pressures equal to or less than 1/2 psig.

Note: Have the gas supply line installed in accordance with local codes, if any. If not, follow ANSI 223.1. Installation should be done by a qualified installer approved and/or licensed as required by the locality. (In the Commonwealth of Massachusetts installation must be performed by a licensed plumber or gas fitter).

Note: A listed (and Commonwealth of Massachusetts approved) 1/2 inch (13 mm) T-handle manual shut-off valve and flexible gas connector are connected to the 1/2 inch (13 mm) control valve inlet.

- **If substituting for these components, please consult local codes for compliance.**

C. Gas Connection

- Refer to Reference Section 15 for location of gas line access in appliance.
- Gas line may be run through knockout(s) provided.
- The gap between supply piping and gas access hole may be caulked with caulk with a minimum of 300°F continuous exposure rating or stuffed with non-combustible, unfaced insulation to prevent cold air infiltration.
- Ensure that gas line does not come in contact with outer wrap of the appliance. Follow local codes.
- Pipe incoming gas line into valve compartment.
- Connect incoming gas line to the 1/2 in. (13 mm) connection on manual shutoff valve.

WARNING! Risk of Fire/Explosion! Support control when attaching pipe to prevent bending gas line.

- A small amount of air will be in the gas supply lines.

WARNING! Risk of Fire/Explosion! Gas build-up during line purge could ignite.

- Purge should be performed by technician certified by NFI or factory-trained.
- Ensure adequate ventilation.
- Ensure there are no ignition sources such as sparks or open flames.

Light the appliance. It will take a short time for air to purge from lines. When purging is complete the appliance will light and operate normally.

WARNING! Risk of Fire, Explosion or Asphyxiation! Check all fittings and connections with a non-corrosive commercially available leak-check solution. **DO NOT** use open flame. Fittings and connections could have loosened during shipping and handling.

WARNING! Risk of Fire! DO NOT change valve settings. This valve has been preset at the factory.

D. High Altitude Installations

NOTICE: If the heating value of the gas has been reduced, these rules do not apply. Check with your local gas utility or authorities having jurisdiction.

When installing above 2000 feet elevation:

- In the USA: Reduce burner orifice 4% for each 1000 feet above 2000 feet.
- In the CANADA: Reduce burner orifice 10% for elevations between 2000 feet and 4500 feet. Above 4500 feet, consult local gas utility.

10 Electrical Information

A. Wiring Requirements

NOTICE: This appliance must be electrically wired and grounded in accordance with local codes or, in the absence of local codes, with **National Electric Code ANSI/NFPA 70-latest edition or the Canadian Electric Code CSA C22.1.**

- This appliance comes standard with a 120 VAC cord assembly which has a female plug in to accommodate all control options and accessories. See Figure 10.2. This is required for use of optional accessories (standing pilot ignition) or proper operation of the appliance (IntelliFire Ignition). An outlet box may be installed in a bottom back corner of the existing solid fuel masonry or factory built fireplace to plug in the cord assembly, or the supplied power cord may be routed out onto the hearth to a nearby outlet.
- A 120VAC circuit for this product must be protected with ground-fault circuit-interrupter protection, in compliance with the applicable electrical codes, when it is installed in locations such as in bathrooms or near sinks.
- Low voltage and 120 VAC voltage cannot be shared within the same wall box.

WARNING! Risk of Shock or Explosion! DO NOT wire 120V to the valve or to the appliance wall switch. Incorrect wiring will damage controls.

- Determine if the appliance uses an Intellifire ignition system or standing pilot ignition system.
- Open the control access panel or remove the decorative front.
- A red or black ignitor button (as shown in Figure 10.1) indicates this appliance is standing pilot ignition.

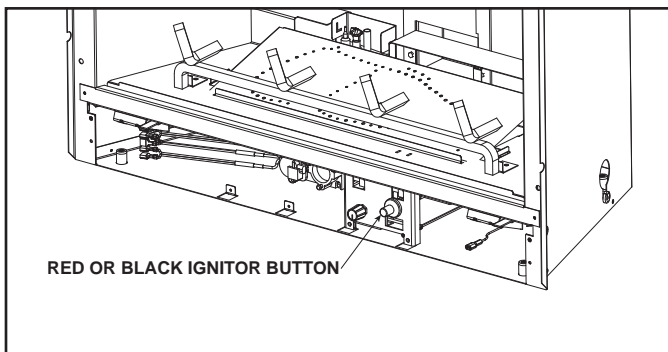

Figure 10.1 Ignitor Button

B. Standing Pilot Ignition System Wiring

- The standing pilot ignition system wiring **DOES NOT** require a 120 VAC supply to operate.
- To power appliance with 120VAC to operate a fan or remote control, an outlet box may be installed in a bottom back corner of the existing solid fuel masonry or factory built fireplace to plug in the cord assembly or the supplied power cord may be routed out onto the hearth to a nearby outlet.

NOTICE: DO NOT wire 120 VAC to the millivolt valve! This will damage the valve.

- If using a thermostat use one compatible with a millivolt gas valve system:
 - Install the thermostat in the location as indicated in the thermostat instructions to ensure proper operation of appliance.
 - Use low resistance thermostat wire for wiring from ignition system to the wall switch and thermostat.
 - Keep wire lengths short as possible by removing any excess wire length.

C. IntelliFire Plus™ Ignition System Wiring

- Wire an outlet box (120VAC) in the bottom back corner of the existing solid fuel masonry or factory built fireplace to plug in the cord assembly. The supplied cord assembly may also be routed out onto the hearth to a nearby outlet.

WARNING! Risk of Shock or Explosion! DO NOT wire IPI controlled appliance junction box to a switched circuit. Incorrect wiring will override IPI safety lockout.

- Refer to Figure 10.2, IPI Wiring Diagram.
- This appliance is equipped with an IntelliFire Plus™ control valve which operates on a 6 volt/1.5 AMP system.
- Plug the 6 volt transformer plug into the appliance junction box to supply power to the unit OR install 4 AA cell batteries (not included) into the battery pack before use.

ON/OFF Switch

- An ON/OFF switch is included with the appliance surround and should be attached to surround/facing. (See Installation instructions for remote control/fronts).
- If desired an additional wall switch or thermostat may be added to system.

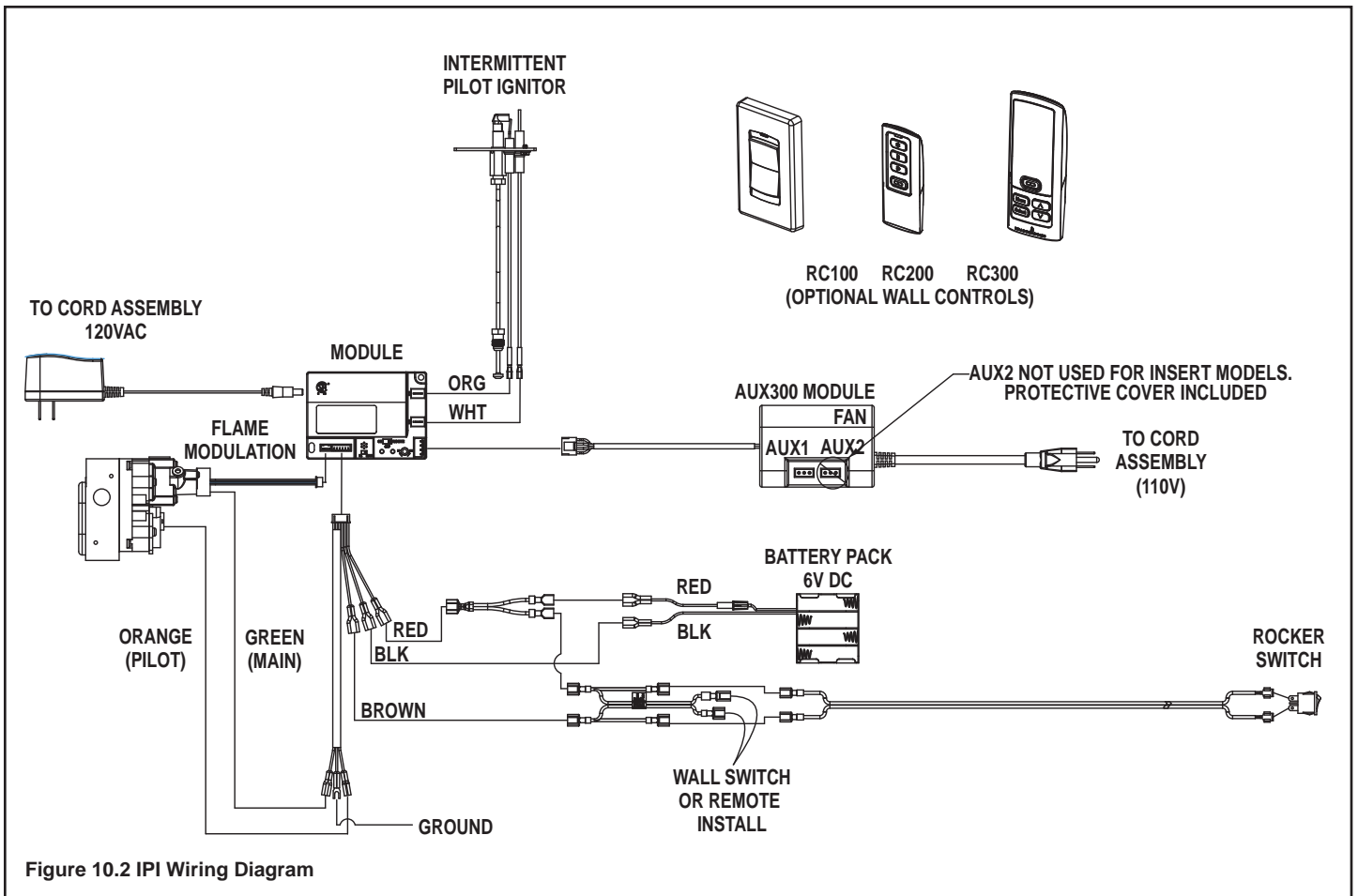

Figure 10.2 IPI Wiring Diagram

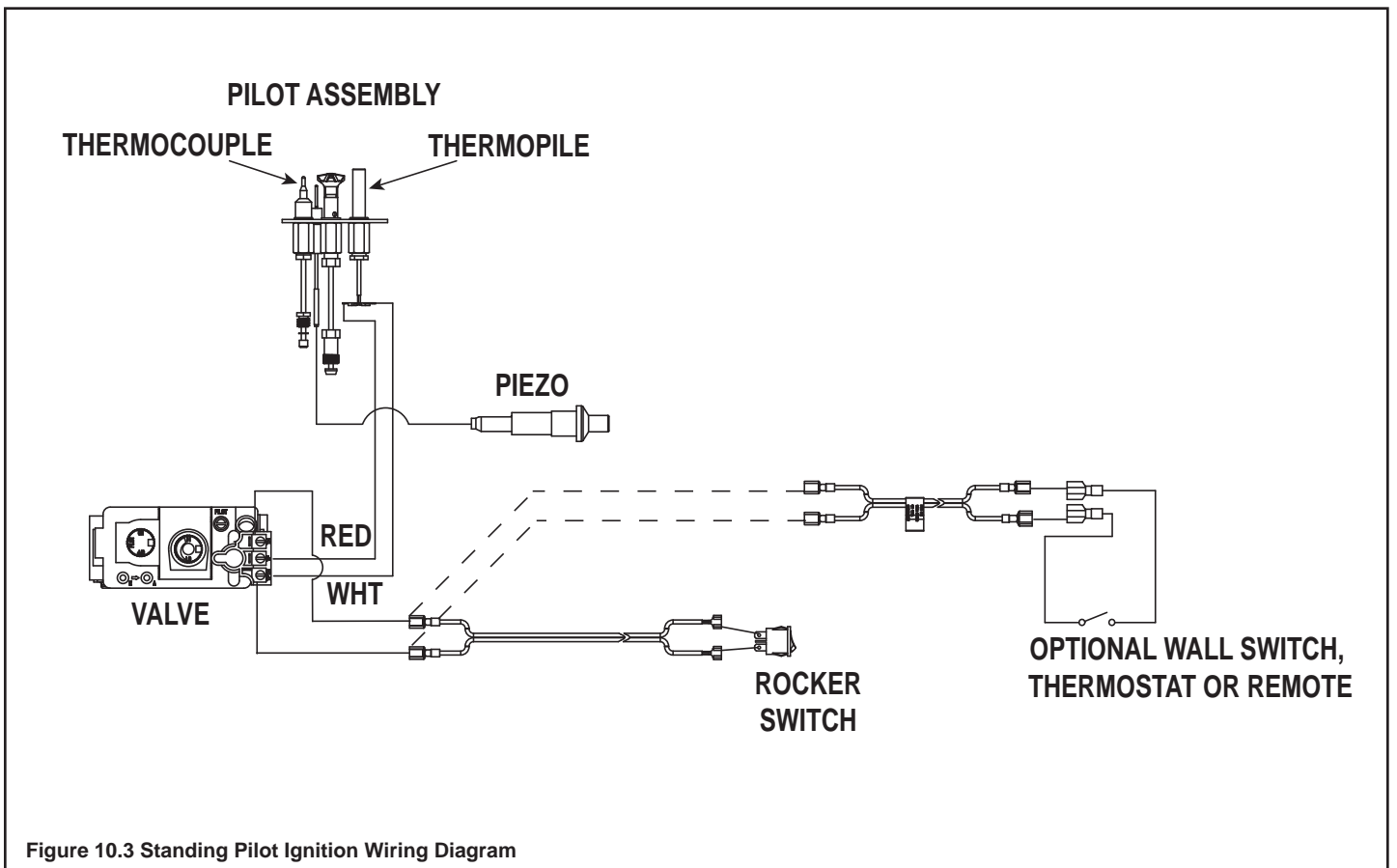

Figure 10.3 Standing Pilot Ignition Wiring Diagram

D. Optional Accessories Requirements

- This appliance may be used with a wall switch, wall mounted thermostat and/or a remote control.
- To connect optional accessories, the supplied cord assembly should be used. See attached Figure 10.4 for a wiring diagram for a blower or remote.

Wiring for optional Hearth & Home Technologies approved accessories should be done now to avoid reconstruction. Follow instructions that come with those accessories.

- Plug the cord into a convenient outlet.
- Must use cord supplied.

- An IntelliFire Plus™ Wireless Controls or WSK-21 wired wall switch may be used with the IntelliFire Plus™ Ignition System. Hearth & Home Technologies recommends that IntelliFire Plus™ wireless controls be used for their features and functionality with the IntelliFire Plus™ ignition system.
- A standard ON/OFF switch is compatible.

WARNING! Risk of Shock! Label all wires prior to disconnection when servicing controls. Wiring errors can cause improper and dangerous operation. Verify proper operation after servicing.

WARNING! Risk of Shock! Replace damaged wire with type 105° C rated wire. Wire must have high temperature insulation.

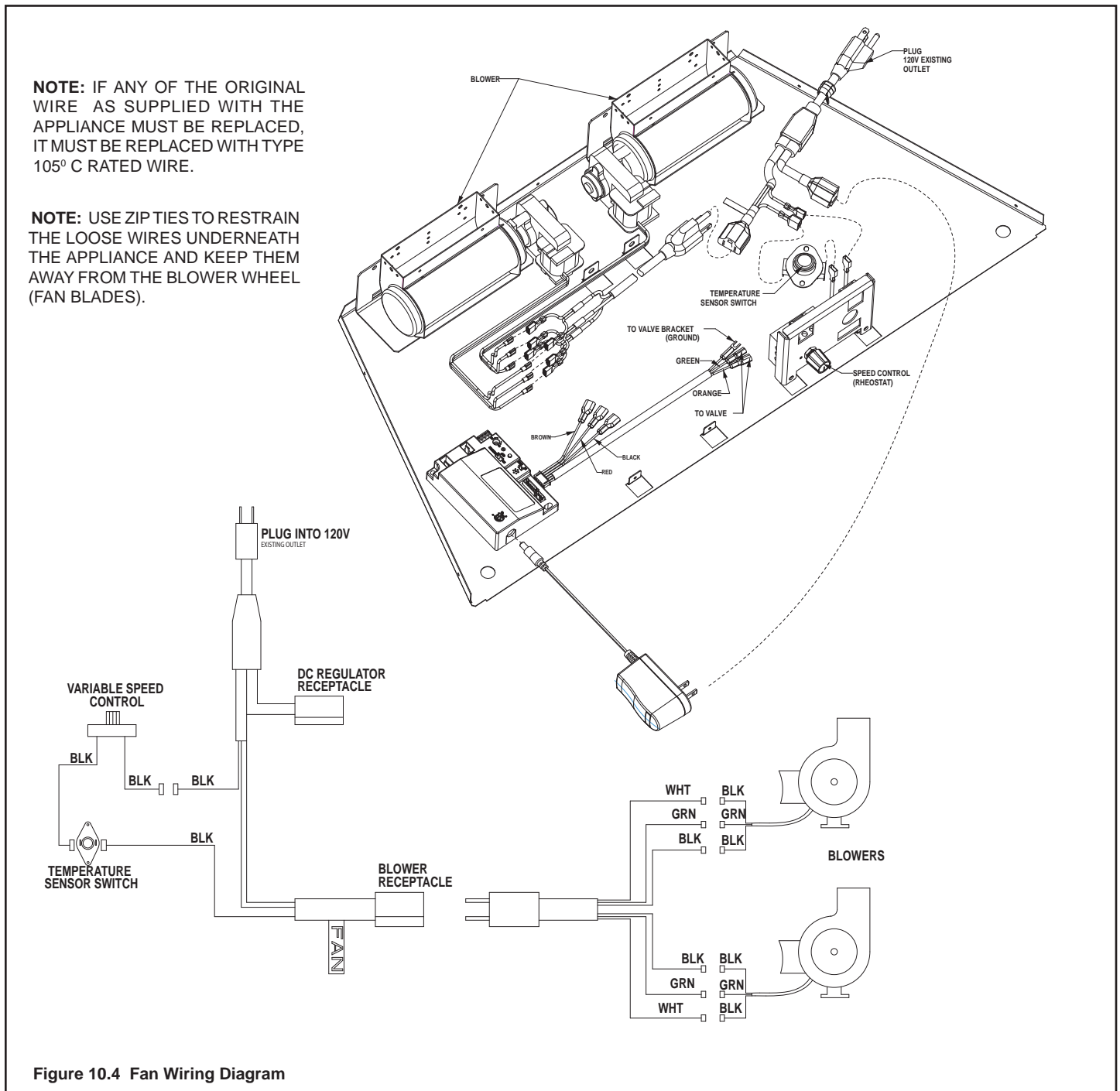

Figure 10.4 Fan Wiring Diagram

E. Fan Wiring with Remote

This appliance may be used with an RC200 or RC300 remote control. See Figure 10.5.

1. Remove cord assembly spades from rheostat and sensor switch.

NOTICE: Fan speed and operation are controlled by the remote control. The sensor switch and rheostat are no longer needed.

2. Plug two cord assembly spade connectors together.
3. Unplug fan cord assembly from standard cord assembly.
4. Plug fan cord assembly into AUX300 module.
5. Plug AUX300 module into the standard cord assembly.

F. Control Module Operation

See Section 2.H for control module operation instructions.

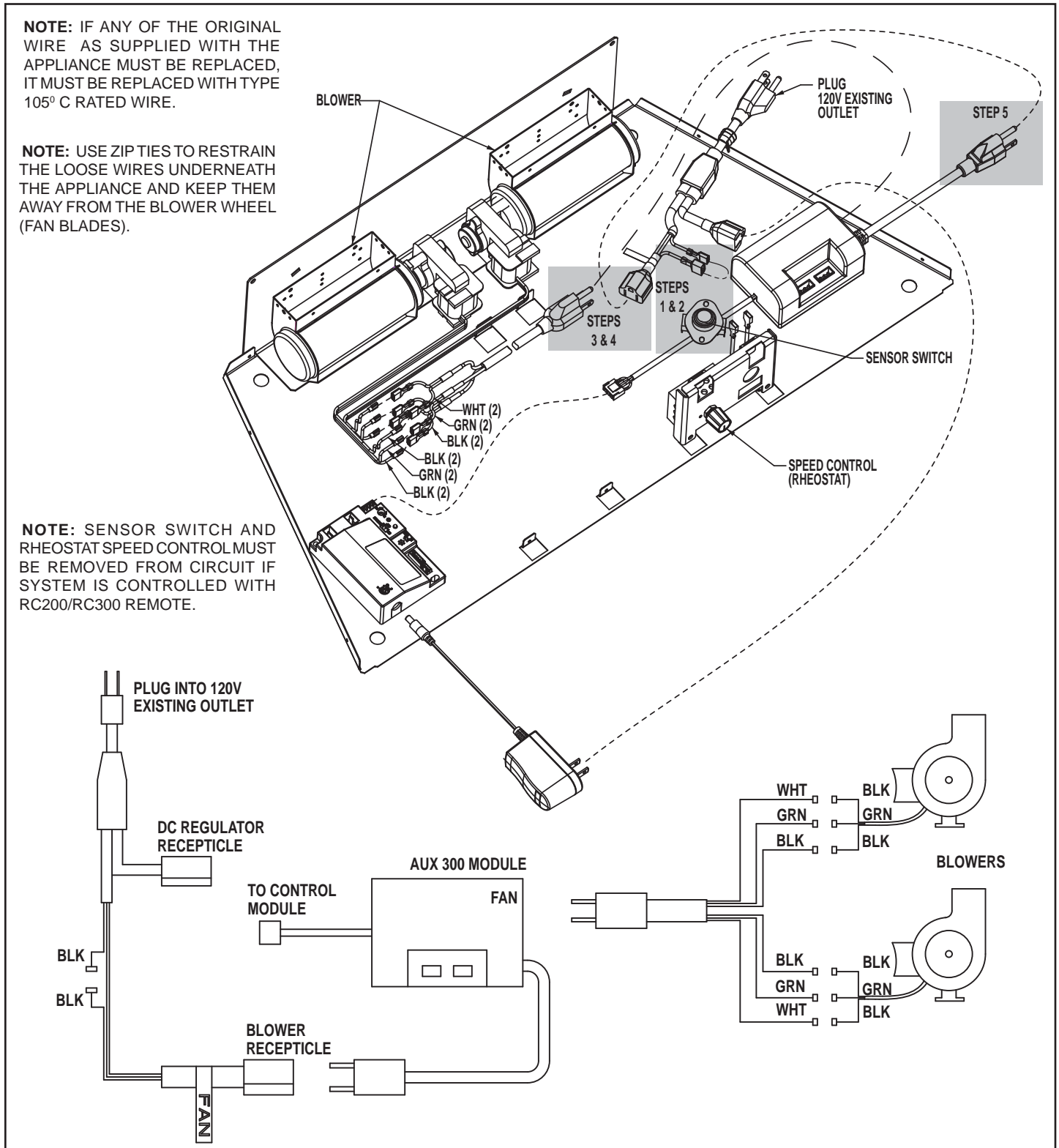

Figure 10.5 Wiring Diagram - Fan with RC200/RC300 Remote

11 Finishing

A. Mantel and Wall Projections

WARNING! Risk of Fire! Comply with all minimum clearances to combustibles as specified. Framing or finishing material closer than the minimums listed must be constructed entirely of noncombustible materials (i.e., steel studs, concrete board, etc).

Clearance to combustible material under the insert is 1/4 inch (6 mm). Clearance from top of fireplace opening for combustibles extending 12 inches max. is 12 inches.

- Use leveling legs to raise insert minimum 1/4 inch (6 mm) above combustible material or outer wrap of factory built firebox.

Combustible facings must not extend behind the insert surround. For non-combustible material specifications refer to section 1.E.

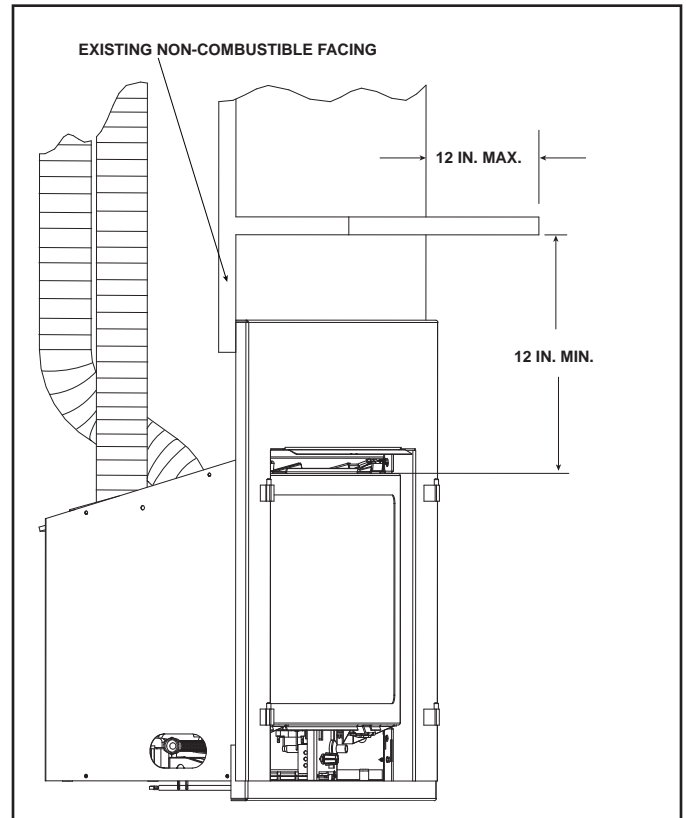

Figure 11.1 Clearances to Mantels or other Combustibles above Appliance

12 Appliance Setup

A. Remove Glass Assembly

See Section 12.H.

B. Remove the Shipping Materials

Remove shipping materials from inside or underneath the firebox.

C. Clean the Appliance

Clean/vacuum any sawdust that may have accumulated inside the firebox or underneath in the control cavity.

D. Accessories

Install approved accessories per instructions included with accessories. Contact your dealer for a list of approved accessories.

WARNING! Risk of Fire and Electric Shock! Use ONLY Hearth & Home Technologies-approved optional accessories with this appliance. Using non-listed accessories could result in a safety hazard and will void the warranty.

E. Place the Lava Rock

WARNING! Risk of Explosion! Follow lava rock placement instructions in manual. **DO NOT** place lava rock on burner. Improperly placed lava rock interferes with proper burner operation.

Lava rock is shipped with this gas appliance. To place the lava rock:

- Lava rock CANNOT be placed on the burner.
- Place lava rock in front of and to the sides of the burner.

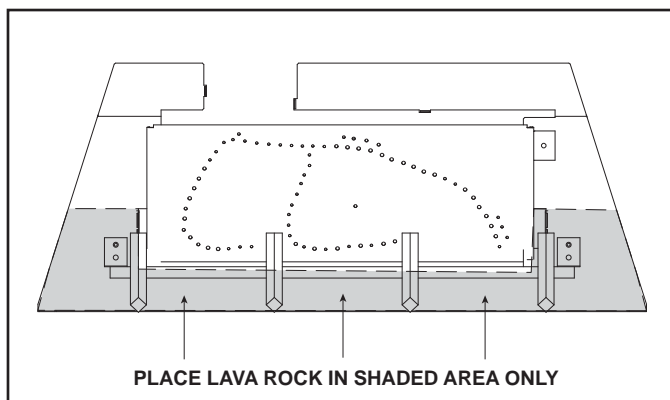

Figure 12.1 Placement of Lava Rock

F. Ember Placement

WARNING! Risk of Explosion! Follow ember placement instructions in manual. **DO NOT** place embers directly over burner ports. Replace ember material annually. Improperly placed embers interfere with proper burner operation.

Ember material is shipped with this gas appliance. To place the ember material:

- Embers CANNOT be placed directly over ports. Care should be taken not to cover the lighting trail of ports (from back to front).
- Place dime-size pieces of Glowing Embers® just in front of the port trail, but not on or in between the ports (see Figure 12.2). Care should be taken so that the ports are not covered. Failure to follow this procedure will likely cause lighting and sooting problems.
- Save the remaining ember materials for use during appliance servicing. The embers provided should be enough for 3 to 5 applications.

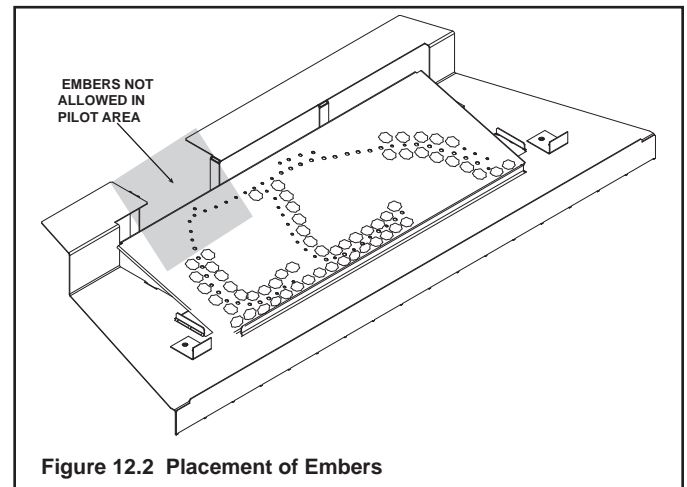

Figure 12.2 Placement of Embers

G. Install the Log Assembly
Log Set Assembly: LOGS-I35
Models: GRAND-I35, GRAND-I35-SP

CAUTION: Logs are fragile, handle with care.



Figure 1. Log Set Installed

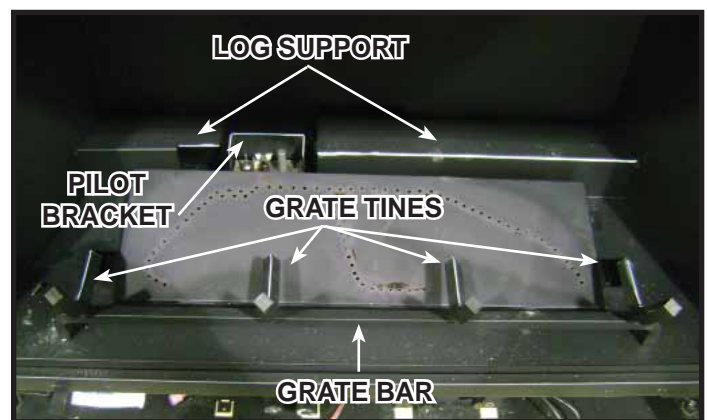

Figure 2. Reference Points



Figure 3. Log #1



Figure 4. Log #1

Log #1 (SRV2205-702) Position Log #1 as shown in Figure 3. Mate the left grate tine with the log groove. Rest the nose of the log on the log support as shown.

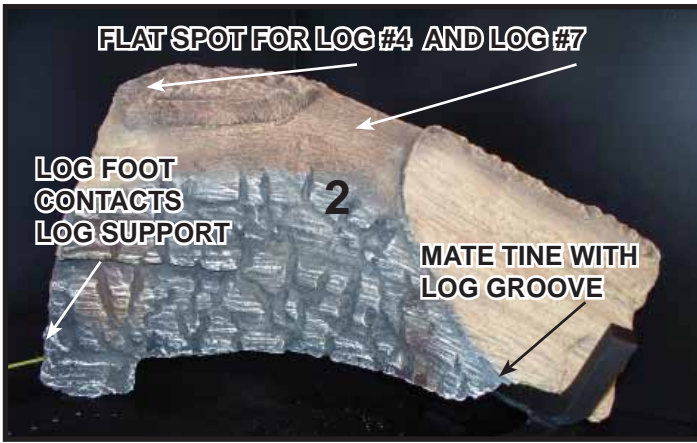

Figure 5. Log #2

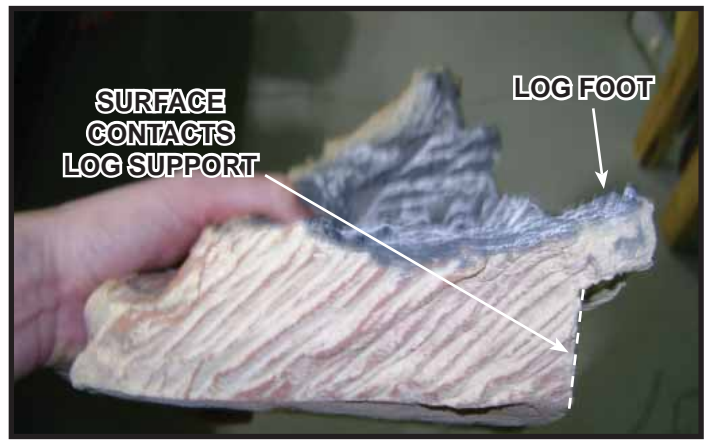

Figure 6. Log #2

Log #2 (SRV2205-701): Position Log #2 as shown in Figure 5. Mate the right grate tine with the log groove. Rest the back of the log on the log support. Rotate the back of the log clockwise until the foot contacts the vertical wall of the log support.

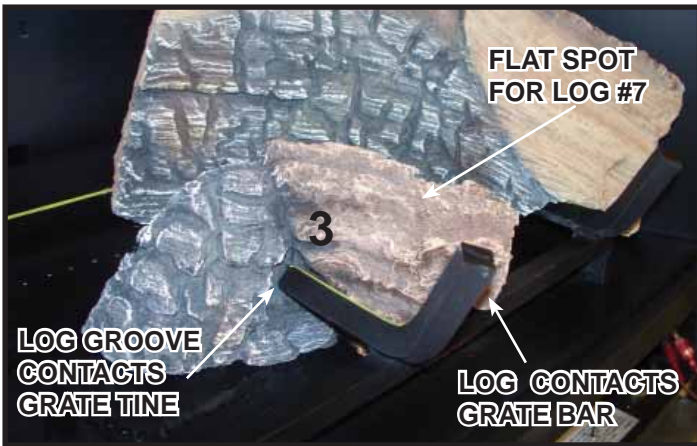

Figure 7. Log #3

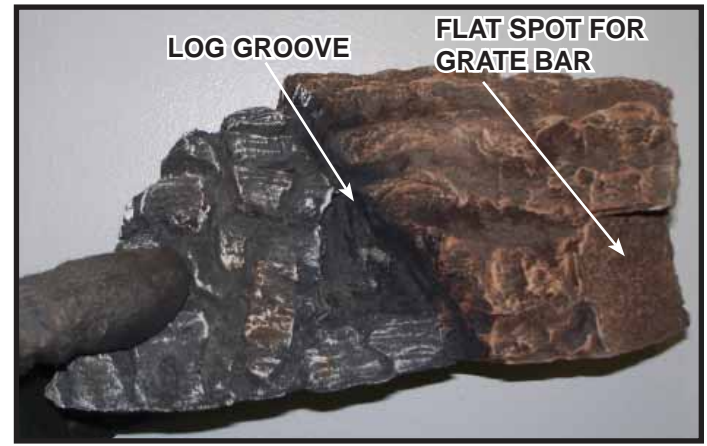

Figure 8. Log #3

Log #3 (SRV2205-705): Position the log groove with the 2nd grate tine from the right. Rotate the right end of the log clockwise until the end of the log contacts the grate bar.



Figure 9. Place Log #4

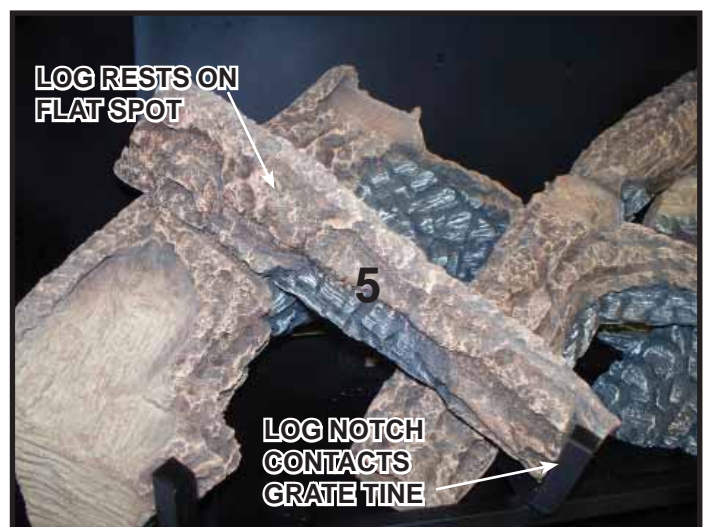

Figure 10. Place Log #5

Log #4 (SRV2205-704): Position Log #4 so that the log groove contacts the second grate tine from the left, as shown in Figure 9. Set the other end of the log on the flat spot located on Log #2. See Figure 5.

Log #5 (SRV2205-710): Mate the notch on Log #5 with the second grate tine from the left as shown in Figure 10. Set the other end of the log on the flat spot of Log #1. See Figure 3.

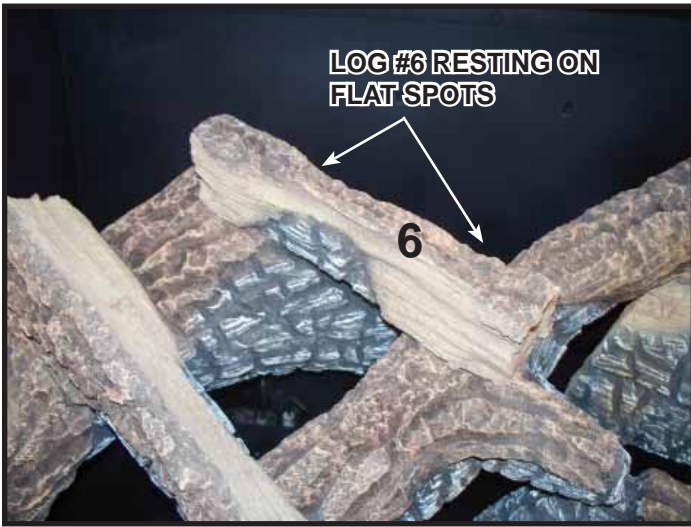

Figure 11. Log #6



Figure 12. Log #7

Log #6 (SRV2205-706): Position Log #6 as shown in Figure 11. Ensure that the correct end of the log rests on the flat spots. The thicker end points forward. Locations of flat spots are indicated in Figure 3 and Figure 9.

Log #7 (SRV2205-703): Position Log #7 as shown in Figure 12. Position the point of the log on the flat spot of Log #3. Place the wider end of the log on the flat spot of Log #2. See Figure 5 and Figure 7 for locations of flat spots.

2205-935B

→ G. Install the Log Assembly
Log Set Assembly: LOGS-I30
Models: Supreme-I30, Supreme-I30-SP, Supreme-I30AU

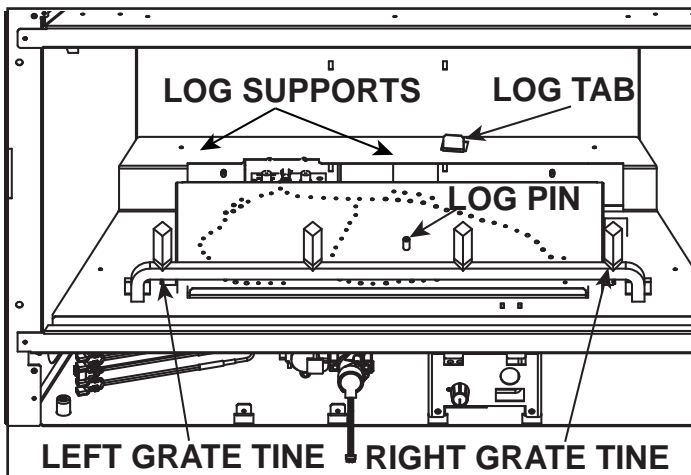

Figure 1.

CAUTION: Logs are fragile, handle with care. Log #1 (SRV2206-701): Bend the log tab into the upright position as shown in Figure 1. Position Log #1 as shown in Figure 2. The left end of the log should rest on the log support. Mate the right end of the log with the right grate tine. Rotate log clockwise, until the right end of the log engages the right grate tine, and the left end of the log touches the log tab shown in Figure 1.



Figure 2. Install Log #1



Figure 3. Log #2

Log #2 (SRV2206-705): Position Log #2 as shown in Figure 3. Mate the slot located on the bottom of Log #2 (Figure 4) with the log pin located on the surface of the burner. Rotate the right end of Log #2 clockwise, until it comes into contact with the grate tine.

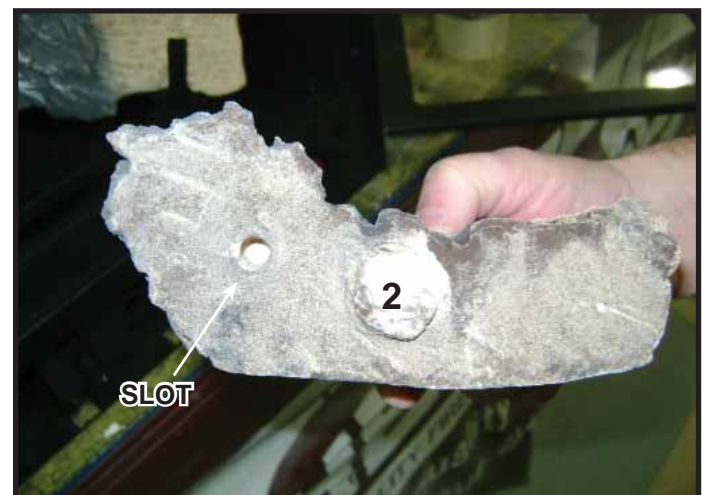

Figure 4. Place Log #2

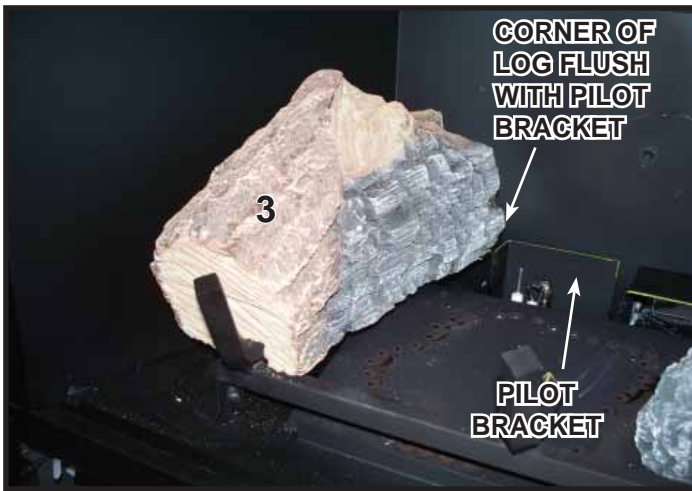

Figure 5. Place Log #3

Log #3 (SRV2206-702): Position Log #3 as shown in Figure 5. Position the grate tine groove, located on the bottom of the log, over the base of the left grate tine. Pull the log forward. The back end of Log #3 rests on the log support. Move the end of Log #3 clockwise until the bottom right corner is flush with the pilot bracket.

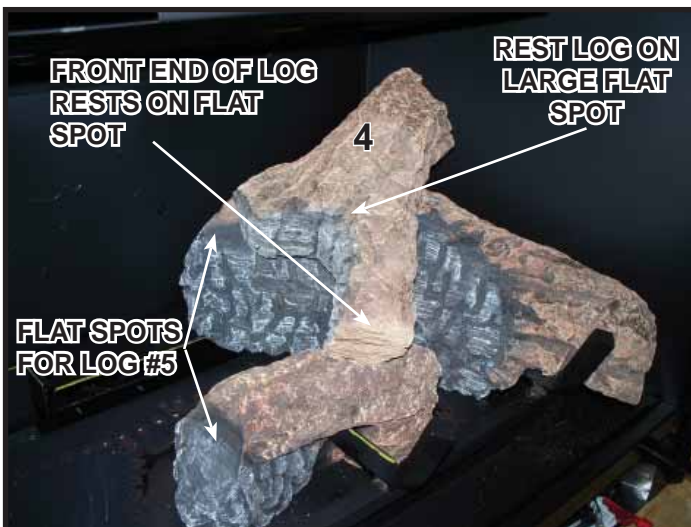

Figure 6. Place Log #4

Log #4 (SRV2206-703): Position Log #4 as shown in Figure 6. See Figure 3 for additional references. Place the thick end of Log #4 on the large flat spot on Log #1. Rest the front end of Log #4 on the flat spot of Log #2.

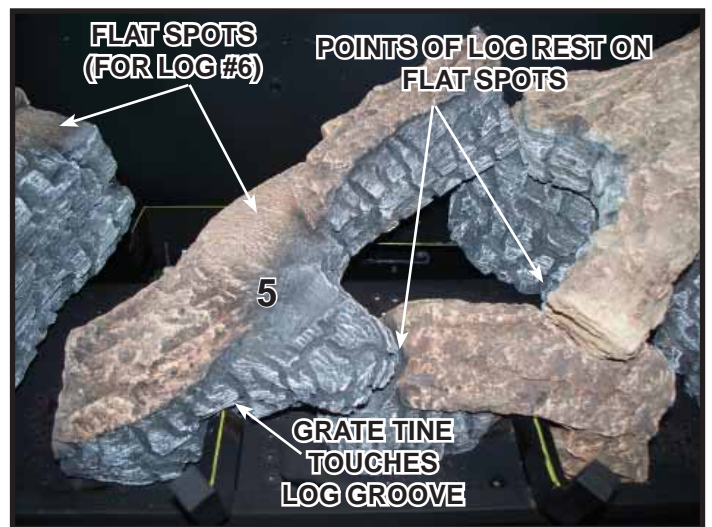

Figure 7. Position Log #5

Log #5 (SRV2206-704): Position Log #5 as shown in Figure 7. See Figure 6 for additional details. Mate the grate tine with the log groove as shown. Position the tips of Log #5 on the flat spots as shown in Figure 6.

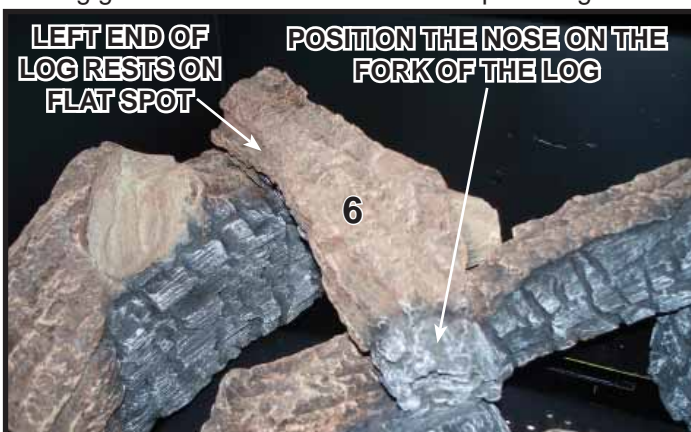

Figure 8. Position Log #6

Log #6 SRV(2206-706): Position Log #6 as shown in Figure 8. See Figure 7 for additional references. Rest the left end of Log #6 on the flat spot of Log #3. Position the nose of Log #6 on the fork of Log #5.



Figure 9. Log Set Installed

2206-935B

H. Fixed Glass Assembly

Removing Fixed Glass Assembly

WARNING! Risk of Asphyxiation! Handle fixed glass assembly with care. Inspect the gasket to ensure it is undamaged and inspect the glass for cracks, chips or scratches.

- **DO NOT** strike, slam or scratch glass.
- **DO NOT** operate fireplace with glass removed, cracked, broken or scratched.
- Replace as a complete assembly.

Removing Fixed Glass Assembly

- The glass assembly fastens to the fireplace in four places. Four of the fastening mechanisms are spring-loaded glass latches. An example of the glass latch is shown in Figure 12.3.
- To release glass assembly, pull the two bottom spring-loaded latches forward and allow them to retract away from the glass assembly. Slide the glass assembly outward and downward until the top latches disengage.

Replacing Fixed Glass Assembly

- Tilt glass assembly toward fireplace and slide glass assembly upward to engage top latches. Verify top latches are fully engaged and then fasten the two bottom latches.

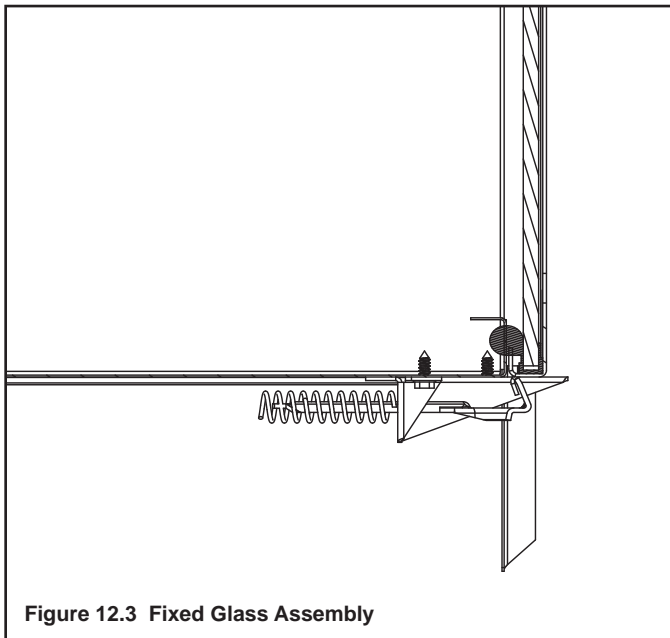

Figure 12.3 Fixed Glass Assembly

I. Air Shutter Setting

Air shutter settings should be adjusted by a qualified service technician at the time of installation. The air shutter is set at the factory for minimum vertical vent run. Adjust air shutter for longer vertical runs. See Figure 12.4.

NOTICE: If sooting occurs, provide more air by opening the air shutter.

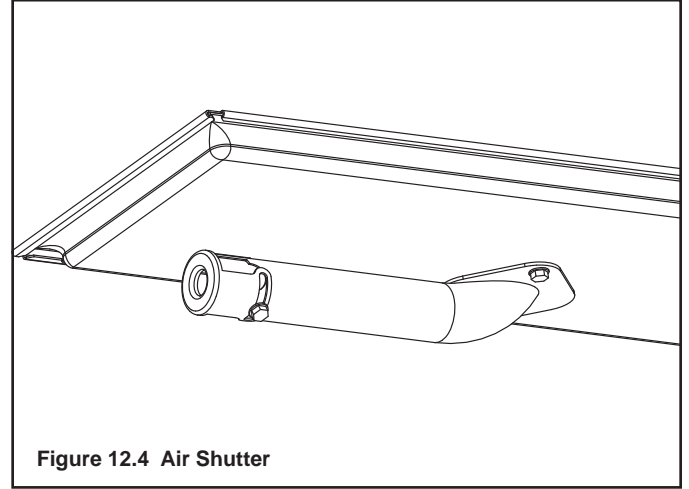

Figure 12.4 Air Shutter

Air Shutter Settings

	NG	LP
SUPREME-I30	3/8 in.	1/2 in.
GRAND-I35	3/8 in.	1/2 in.

13 Troubleshooting

With proper installation, operation, and maintenance your gas appliance will provide years of trouble-free service. If you do experience a problem, this troubleshooting guide will assist a qualified technician in the diagnosis of a problem and the corrective action to be taken. This troubleshooting guide can only be used by a qualified technician. Contact your dealer to arrange a service call by a qualified technician.

A. Standing Pilot Ignition System

Symptom	Possible Causes	Corrective Action
1. After repeated triggering of the red or black piezo ignitor button, the spark ignitor will not light the pilot.	A. No gas or low gas pressure.	Check the remote shut-off valves from the appliance. Usually, there is a valve near the gas main. There can be more than one valve between the appliance and the main.
	B. No lp in tank.	Check the LP (propane) tank. You may be out of fuel.
	C. Ignitor.	Check the spark at the electrode and pilot. If no spark and electrode wire is properly connected, replace the ignitor. Verify that there is no short in electrode wire.
	D. Pilot or misaligned electrode (spark at electrode).	Using match, light the pilot. If the pilot lights, turn off the pilot and trigger the piezo ignitor button again. If the pilot lights, an improper gas/air mixture caused the bad lighting and a longer purge period is recommended. If the pilot will not light, ensure the gap at the electrode and pilot is one-eighth in. to have a strong spark. If the gap is OK, replace the pilot.
2. The pilot will not stay lit after carefully following the lighting instructions.	A. Thermocouple.	Check that the pilot flame impinges on the thermocouple. Adjust the pilot for proper flame impingement. Ensure that the thermocouple connection at the gas valve is fully inserted and tight (hand tighten plus 1/4 turn). Verify proper voltage output from the thermocouple to the valve. Place one millivolt meter lead wire on the thermocouple copper lead. Place the second lead wire on the solder button on the back of the valve (blue wire). Start the pilot and hold the valve knob in. The millivolt reading should read 8-16 millivolts. If millivolt reading is less than 8 millivolts, replace thermocouple.
	B. Improper gas inlet pressure.	Natural gas should be 5-10 in. w.c. LP should be 11-13 in. w.c. Verify pressure with manometer.
	C. Valve.	If the thermocouple is producing 8-16 millivolts, replace control valve.
3. The pilot is burning, there is no burner flame, the valve knob is in the ON position, and the ON/OFF switch is in the ON position.	A. ON/OFF switch or wires.	Check the ON/OFF switch and wires for proper connections. Place the jumper wires across the terminals at the ON/OFF switch. If the burner comes on, replace the ON/OFF switch. If the ON/OFF switch is OK, place the jumper wires across the ON/OFF switch wires at the gas valve. If the burner comes on, the wires are faulty or connections are bad.
	B. Thermopile may not be generating sufficient millivoltage.	Check that the pilot flame impinges thermopile properly. Be sure the wire connections from the thermopile at the gas valve terminals are tight and that the thermopile is fully inserted into the pilot bracket. Check the thermopile with a millivolt meter. Take the reading at TH-TP&TP terminals of the gas valve. The meter should read 350 millivolts minimum, while holding the valve knob depressed in the pilot position, with the pilot lit, and the ON/OFF switch in the OFF position. Replace the thermopile if the reading is below the specified minimum. With the pilot in the ON position, disconnect the thermopile leads from the valve. Take a reading at the thermopile leads. The reading should be 350 millivolts minimum. Replace the thermopile if the reading is below the minimum.

Troubleshooting (continued)

Symptom	Possible Cause	Corrective Action
3. (Continued)	C. Valve.	Turn the valve knob to the ON position. Place the ON/OFF switch in the ON position. Take a reading with a millivolt meter at the thermopile terminals. The millivolt meter should read greater than 125mV. If the reading is acceptable, and if the burner does not come on, replace the gas valve.
	D. Plugged burner orifice.	Check the burner orifice for stoppage. Remove stoppage.
	E. Wall switch or wires.	Check the wall switch and wires for proper connections. Place the jumper wires across the terminals at the wall switch. If the burner comes on, replace the wall switch. If the wall switch is OK, place the jumper wires across the wall switch wires at the gas valve. If the burner comes on, the wires are faulty or connections are bad.
4. Frequent pilot outage problem.	A. Pilot flame may be too high or too low, or blowing out (high pressure), causing pilot safety to drop out.	Clean thermocouple and adjust the pilot flame for proper flame impingement. Follow lighting instructions carefully.
5. The pilot and main burner extinguish while in operation.	A. No LP in tank.	Check the LP (propane) tank. Refill the fuel tank.
	B. Improper gas inlet pressure.	Natural gas should be 5-14 in. w.c. LP should be 10-14 in. w.c. Verify pressure with manometer.
	C. Inner vent pipe leaking exhaust gases back into the system.	Check venting system for damage. Replace/repair improperly assembled pipe sections.
	D. Glass installed improperly.	Check to ensure glass is installed properly. Replace fixed glass panel assembly.
	E. Thermopile or thermocouple.	Replace pilot if necessary.
	F. Improper vent cap installation.	Check for proper installation and freedom from debris or blockage.
6. Glass soots.	A. Flame impingement.	Adjust the log set so that the flame does not excessively impinge on it. Refer to log instructions.
	B. Improper air shutter setting.	Refer to manual for shutter set points. Ensure that set point is correct for appliance/gas type. If unit has adjustable shutter, it may be necessary to increase shutter opening.
	C. Debris around air shutter.	Inspect the opening at the base of the burner. NO MATERIAL SHOULD BE PLACED IN THIS OPENING.
7. Flame burns blue and lifts off burner.	A. Insufficient oxygen being supplied.	Ensure that the vent cap is installed properly and free of debris. Ensure that the vent system joints are tight and have no leaks. Ensure that no debris has been placed at the base of, or in the area of the air holes in the center of the base pan beneath the burner. Ensure that the glass is tightened properly on the unit, particularly on top corners.

B. IntelliFire Plus™ Ignition System

Symptom	Possible Cause	Corrective Action
1. Pilot won't light. The ignitor/module makes noise, but no spark.	A. Incorrect wiring.	Verify "S" wire (white) for sensor and "I" wire (orange) for ignitor are connected to correct terminals on module and pilot assembly.
	B. Loose connections or electrical shorts in the wiring.	Verify no loose connections or electrical shorts in wiring from module to pilot assembly. Verify connections underneath pilot assembly are tight; also verify igniter and flame sense wires are not grounding out to metal chassis, pilot burner, pilot enclosure, mesh screen if present, or any other metal object.
	C. Ignitor gap is too large.	Verify gap of igniter to right side of pilot hood. The gap should be approximately .17 in. or 1/8 in. (3 mm).
2. Pilot won't light, there is no noise or spark.	A. No power, transformer installed incorrectly, or depleted batteries.	Verify that transformer is installed and plugged into module. Check voltage of transformer at connection to module. Acceptable readings of a good transformer are between 6.4 and 6.6 volts AC. Battery power supply voltage must be at least 4 volts. If below 4 volts, replace batteries.
	B. A shorted or loose connection in wiring configuration or wiring harness.	Remove and reinstall the wiring harness that plugs into module. Verify there is a tight fit. Verify pilot assembly wiring to module. Remove and verify continuity of each wire in wiring harness. Replace any damaged components.
	C. Improper wall switch wiring.	Verify that 120/VAC power is "ON" to junction box.
	D. Module not grounded.	Verify black ground wire from module wire harness is grounded to metal chassis of appliance.
3. Pilot sparks, but Pilot will not light.	A. Gas supply.	Verify that incoming gas line ball valve is "open". Verify that inlet pressure reading is within acceptable limits.
	B. Ignitor gap is too large.	Verify gap of igniter to right side of pilot hood. The gap should be approximately .17 in. or 1/8 in. (3 mm).
	C. Module is not grounded.	Verify module is securely grounded to metal chassis of appliance.
	D. Pilot valve solenoid	Verify that 1.5 to 1.8 VDC is supplied to pilot solenoid from module. If below 1.5 volts, replace module. If 1.5 volts or greater, replace valve.
4. Pilot lights but continues to spark, and main burner will not ignite. (If the pilot continues to spark after the pilot flame has been lit, flame rectification has not occurred.)	A. A shorted or loose connection in flame sensing rod.	Verify all connections to wiring diagram in manual. Verify connections underneath pilot assembly are tight. Verify flame sense or igniter wires are not grounding out to metal chassis, pilot burner, pilot enclosure or screen if present, or any other metal object.
	B. Poor flame rectification or contaminated flame sensing rod.	With fixed glass assembly in place, verify that flame is engulfing flame sensing rod on left side of pilot hood. Flame sensing rod should glow shortly after ignition. With a multi-meter, verify that current in series between module and sense lead is at least 0.14 microamps. Verify correct pilot orifice is installed and gas inlet is set to pressure specifications. Clean flame sensing rod with emery cloth to remove any contaminants that may have accumulated on flame sensing rod.
	C. Module is not grounded.	Verify module is securely grounded to metal chassis of appliance. Verify that wire harness is firmly connected to the module.
	D. Damaged pilot assembly or contaminated flame sensing rod.	Verify that ceramic insulator around the flame sensing rod is not cracked, damaged, or loose. Verify connection from flame sensing rod to white sensor wire. Clean flame sensing rod with emery cloth to remove any contaminants that may have accumulated on flame sensing rod. Verify continuity with a multi-meter with ohms set at lowest range. Replace pilot if any damage is detected.

14 Reference Materials

A. Appliance Dimension Diagram

Dimensions are actual appliance dimensions. Use for reference only.

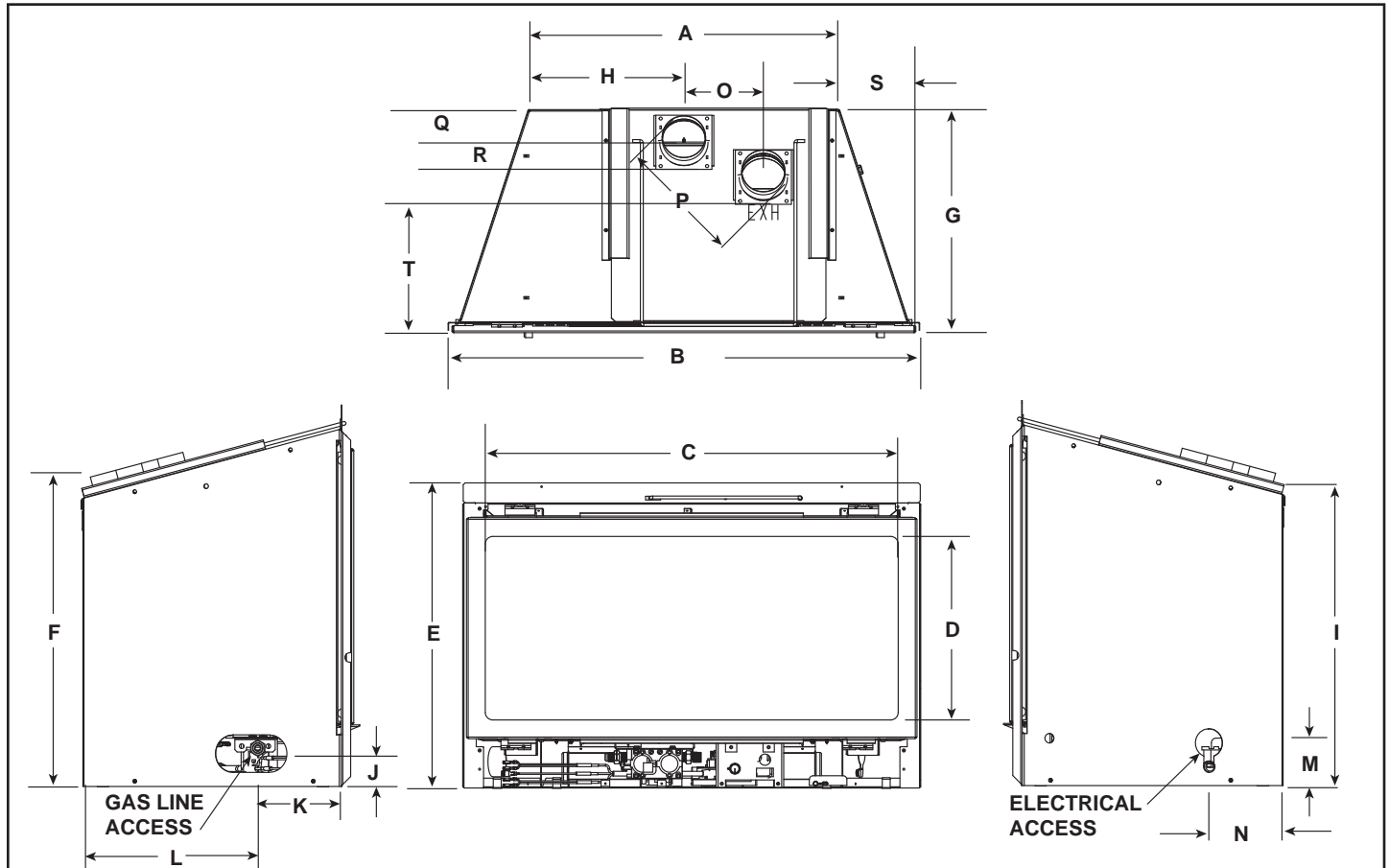

MODEL DIMENSIONS				
Location	GRAND-I35		SUPREME-I30	
	Inches	Millimeters	Inches	Millimeters
A	23-1/2	597	20-3/16	513
B	34-5/8	879	30-1/2	775
C	31-9/16	802	27-7/16	697
D	15-11/16	398	12-13/16	325
E	24	610	20-1/2	521
F	21-1/16	535	17-5/8	448
G*	15-7/8	403	14-5/8	372
H	11-3/4	298	10-1/8	257
I	20-3/8	518	17	432
J	1-3/4	44	1-3/4	44

MODEL DIMENSIONS				
Location	GRAND-I35		SUPREME-I30	
	Inches	Millimeters	Inches	Millimeters
K	4-13/16	122	4-13/16	122
L	10-1/16	256	9	229
M	2-1/4	57	2-1/4	57
N	5	127	3-15/16	100
O	5-1/8	130	5-3/16	132
P	8	203	8	203
Q	1-13/16	46	1-3/4	44
R	2-1/4	57	2-1/4	57
S	4-13/16	122	4-7/16	113
T	10-1/2	267	9-1/2	241

*Note: Location G on Figure 14.1 is measuring the appliance depth, for installation depth reference Location G on Figure 5.1.

Figure 14.1 Appliance Dimensions

B. Vent Kits Components

Direct Vent Flex Liner Kits (see Figure 14.2)

LINK-DV30B: Masonry 3 inch flex liner kit. Expands to 30 feet. Includes: two liners, termination cap, flashing, and link adapter.

LINK-DV4-30B: Masonry 3 inch flex liner kit. Expands to 30 feet and 4 feet respectively. Includes: two liners, termination cap, flashing, and link adapter.

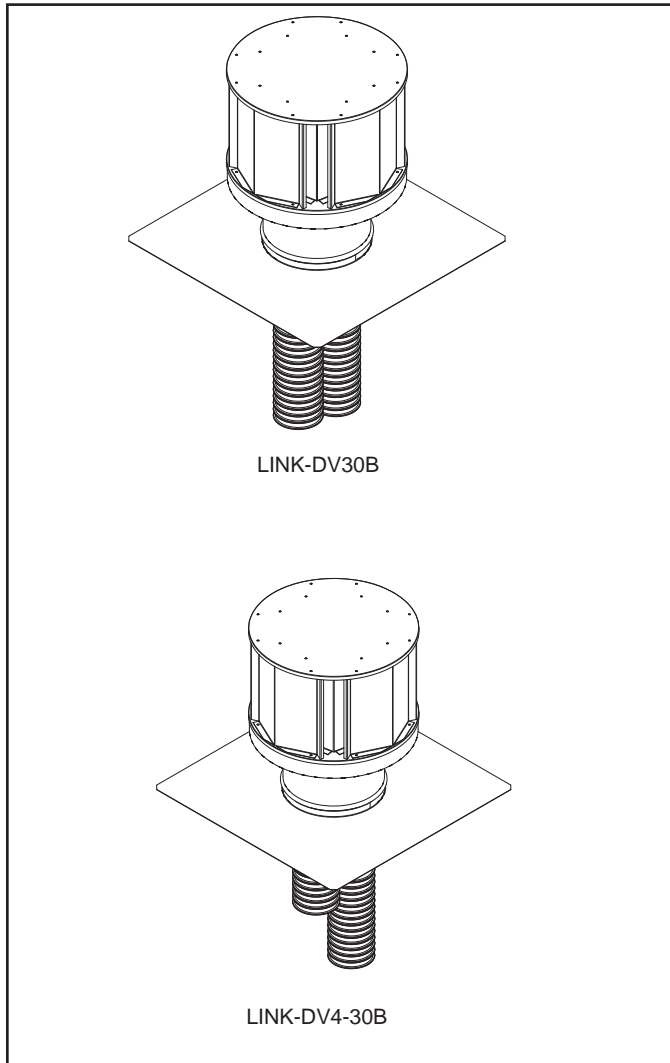

Figure 14.2 Direct Vent Flex Liner Kits

Direct Vent Flex Liner Accessory Kits (see Figure 14.3)

Flash-Damp: Zero clearance damper flashing kit for use with the LINK-DV30B or LINK-DV4-30B liner kits.

LINK-ZC-ADP: Zero clearance chimney adapter

DV-46DVA-GK: Adapter kit - It is permissible to use DV-46DVA-GK to connect colinear flex vent to SL-D vent pipe to extend the run.

FLEX3-30: One 3 inch flexible liner expands to 30 feet.

FLEX-CNCT: Connector kit - 3 inch liner to 3 inch liner, one connector per kit.

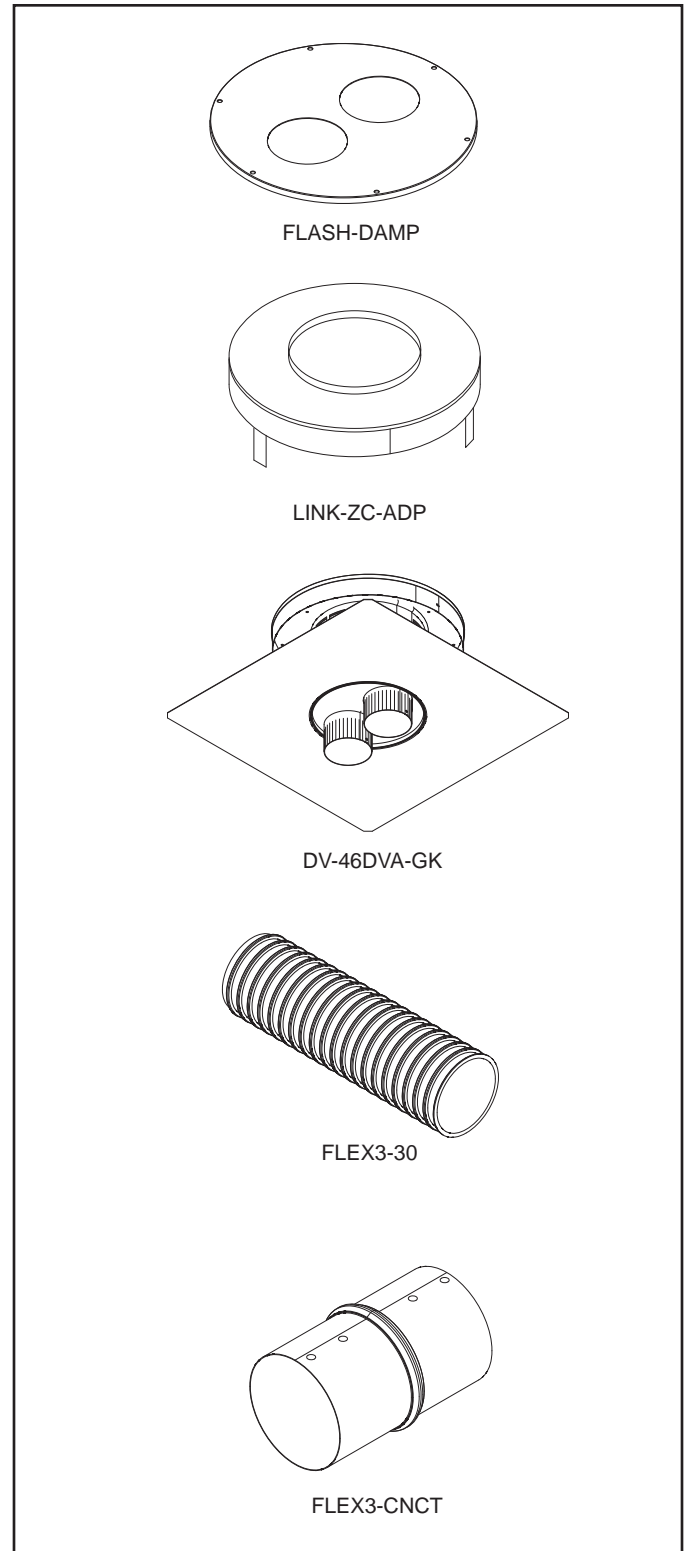
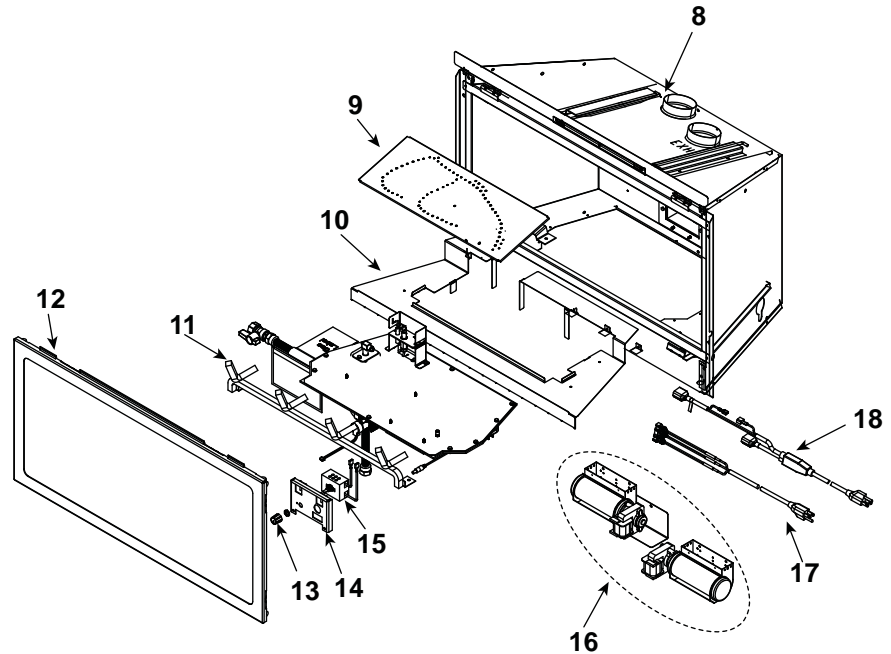

Figure 14.3 Direct Vent Flex Liner Accessory Kits

Log Set Assembly



IMPORTANT: THIS IS DATED INFORMATION. When requesting service or replacement parts for your appliance please provide model number and serial number. All parts listed in this manual may be ordered from an authorized dealer.



Stocked at Depot

ITEM	DESCRIPTION	COMMENTS	PART NUMBER	Stocked at Depot
	Log Assembly		LOGS-I35	Y
1	Log 1		SRV2205-702	
2	Log 2		SRV2205-701	
3	Log 3		SRV2205-705	
4	Log 4		SRV2205-704	
5	Log 5		SRV2205-710	
6	Log 6		SRV2205-706	
7	Log 7		SRV2205-703	
8	Termination Plate Assembly		2205-012	
	Flex Pipe Handle		438-351	
	Gasket		2206-401	
9	Burner Assembly		2205-007	Y
10	Base Pan		2205-106	
11	Grate Assembly		2205-016	
12	Glass Door Assembly		GLA-2205	Y
13	Rheostat Knob		100-512	Y
14	Control Panel		2205-129	
15	On/Off Rheostat		2206-800	Y
16	Blower Assembly		GFK-210	
17	Power Cord Assembly		2206-068	Y
18	Cord Assembly		2201-017	Y

Additional service part numbers appear on following page.

Log Set Assembly

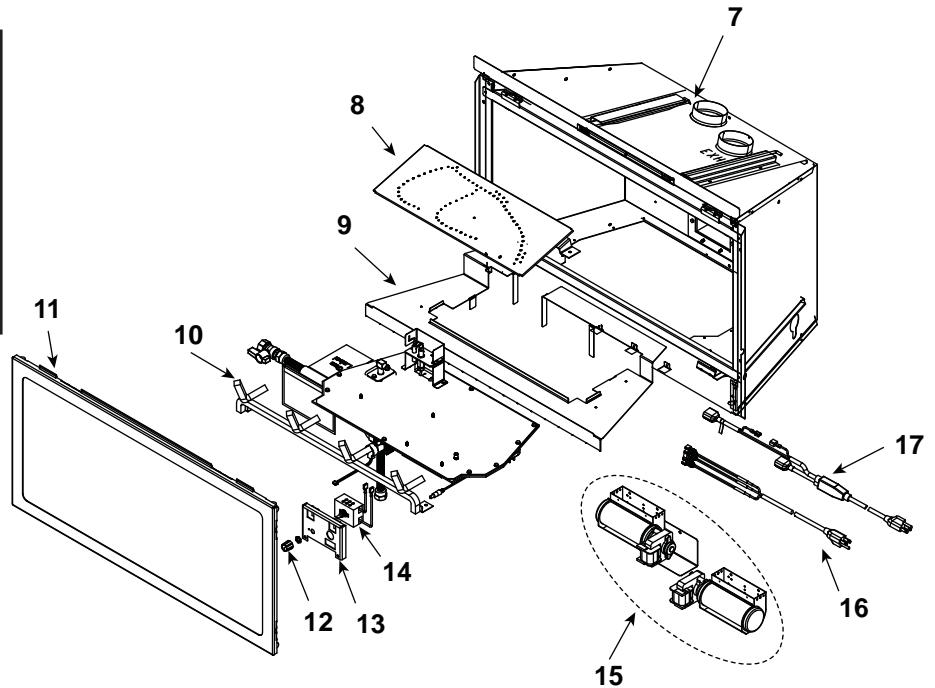
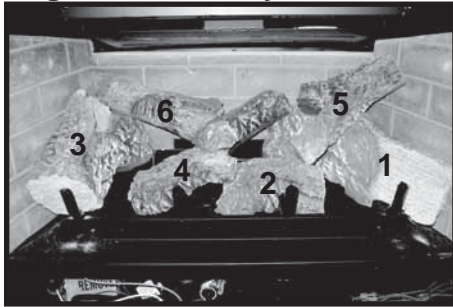

IMPORTANT: THIS IS DATED INFORMATION. When requesting service or replacement parts for your appliance please provide model number and serial number. All parts listed in this manual may be ordered from an authorized dealer.



Stocked at Depot

ITEM	DESCRIPTION	COMMENTS	PART NUMBER	
	Log Assembly		LOGS-I30	Y
1	Log 1		SRV2206-701	
2	Log 2		SRV2206-705	
3	Log 3		SRV2206-702	
4	Log 4		SRV2206-704	
5	Log 5		SRV2206-703	
6	Log 6		SRV2206-706	
7	Termination Plate Assembly		2206-012	
	Flex Pipe Handle		438-351	
	Gasket		2206-401	
8	Burner Assembly		2206-007	Y
9	Base Pan		2206-106	
10	Grate Assembly		2206-016	
11	Glass Door Assembly		GLA-2206	Y
12	Rheostat Knob		100-512	Y
13	Control Panel		2205-129	
14	On/Off Rheostat		2206-800	Y
15	Blower Assembly		GFK-210	
16	Power Cord Assembly		2206-068	Y
17	Cord Assembly		2201-017	Y

Additional service part numbers appear on following page.

#19 IPI Valve Assembly

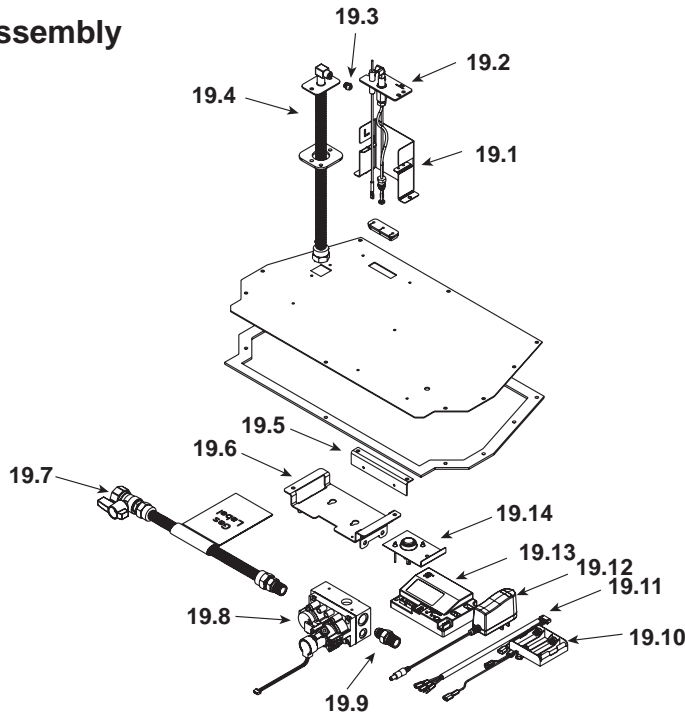

IMPORTANT: THIS IS DATED INFORMATION. When requesting service or replacement parts for your appliance please provide model number and serial number. All parts listed in this manual may be ordered from an authorized dealer.



Stocked at Depot

ITEM	DESCRIPTION	COMMENTS	PART NUMBER	Stocked at Depot
19.1	Pilot Bracket		2206-105	
19.2	Pilot Assembly NG		2198-014	Y
	Pilot Assembly LP		2198-015	Y
19.3	Orifice NG (#33C)	GRAND-I35	582-833	Y
	Orifice LP (#50C)		582-850	Y
	Orifice NG (#35C)	SUPREME-I30	582-835	Y
	Orifice LP (#51C)		582-851	Y
19.4	18" Flex Tube Assembly		530-320A	Y
19.5	Bracket, Control Panel		2205-128	
19.6	Valve Bracket		2205-146	
19.7	Flex Ball Valve Assembly		302-320A	Y
19.8	Valve NG		2166-302	Y
	Valve LP		2166-303	Y
19.9	Brass Connector	Pkg of 5	303-315/5	Y
19.10	Battery Pack**		2166-323	Y
19.11	Wire Harness		2166-304	Y
19.12	Power Supply		2166-305	Y
19.13	Module		2166-307	Y
19.14	Temp Sensor Assembly		046-018A	Y

**Fuse for battery pack can be sourced locally, not a warranty item. Specs are 500mA~10A 3/4" long

Additional service part numbers appear on following page.

#19 Standing Pilot Valve Assembly

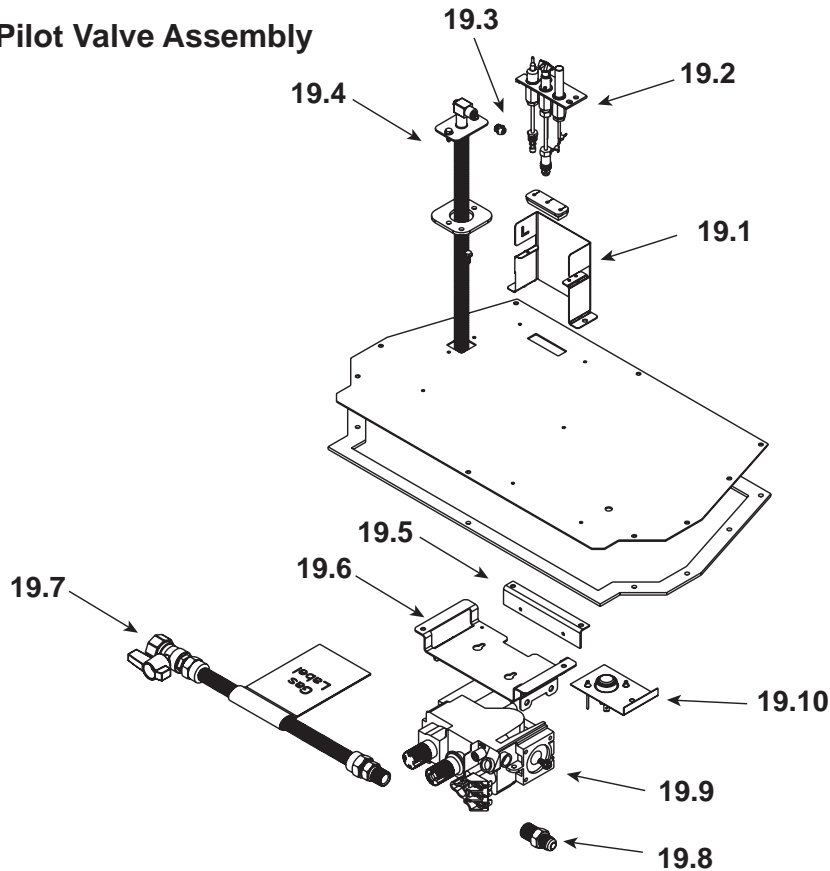

IMPORTANT: THIS IS DATED INFORMATION. When requesting service or replacement parts for your appliance please provide model number and serial number. All parts listed in this manual may be ordered from an authorized dealer.



Stocked at Depot

ITEM	DESCRIPTION	COMMENTS	PART NUMBER	Stocked at Depot
19.1	Pilot Bracket		2206-105	
19.2	Pilot Assembly NG		2103-010	Y
	Pilot Assembly LP		2103-011	Y
	Pilot Tube		SRV485-301	Y
	Thermocouple		446-511	Y
	Thermopile		2103-512	Y
19.3	Orifice NG (#33C)		582-833	Y
	Orifice LP (#50C)		582-850	Y
19.4	18" Flex Tube Assembly		530-302A	Y
19.5	Control Panel Bracket		2205-128	
19.6	Valve Bracket		2205-146	
19.7	Flex Ball Valve Assembly		302-320A	Y
19.8	Brass Connector	Pkg of 5	303-315/5	Y
19.9	Valve NG		2166-300	Y
	Valve LP		2166-301	Y
19.10	Temp Sensor Assembly		046-018A	Y

Additional service part numbers appear on following page.

